



Product Service

# CERTIFICATE

No. Z2 083334 0048 Rev. 10

**Holder of Certificate:** **Ningbo Ulica Solar Co., Ltd.**

NO.181-197, Shanshan Road  
Wangchun Industrial District  
315177 Ningbo  
PEOPLE'S REPUBLIC OF CHINA

**Certification Mark:**



**Product:**

**Crystalline Silicon Terrestrial Photovoltaic (PV) Modules**  
**Mono-Crystalline Silicon Photovoltaic Module**

The product was tested on a voluntary basis and complies with the essential requirements. The certification mark shown above can be affixed on the product. It is not permitted to alter the certification mark in any way. In addition, the certification holder must not transfer the certificate to third parties. This certificate is valid until the listed date, unless it is cancelled earlier. All applicable requirements of the testing and certification regulations of TÜV SÜD Group have to be complied. For details see: [www.tuvsud.com/ps-cert](http://www.tuvsud.com/ps-cert)

**Test report no.:** 704061806602-10

**Valid until:** 2026-09-16

**Date,** 2021-09-17

( Zhulin Zhang )

# CERTIFICATE

No. Z2 083334 0048 Rev. 10

**Model(s):**

**1000 V DC system voltage Single Glass modules:**

- UL-xxxM-72, xxx= 330 to 390 in step of 5
- UL-xxxM-60, xxx= 275 to 325 in step of 5
- UL-xxxM-54, xxx= 245 to 290 in step of 5
- UL-xxxM-48, xxx= 220 to 260 in step of 5
- UL-xxxM-24, xxx= 110 to 130 in step of 5

**1500 V DC system voltage Single Glass modules:**

- UL-xxxM-72HV, xxx= 330 to 390 in step of 5
- UL-xxxM-60HV, xxx= 275 to 325 in step of 5
- UL-xxxM-54HV, xxx= 245 to 290 in step of 5
- UL-xxxM-48HV, xxx= 220 to 260 in step of 5
- UL-xxxM-24HV, xxx= 110 to 130 in step of 5

**Half cell 1000 V DC system voltage Single Glass modules:**

- UL-xxxM-144, xxx= 370 to 415 in step of 5
- UL-xxxM-120, xxx= 305 to 345 in step of 5
- UL-xxxM-108, xxx= 275 to 315 in step of 5
- UL-xxxM-96, xxx= 245 to 275 in step of 5
- UL-xxxM-144, xxx= 420 to 460 in step of 5
- UL-xxxM-120, xxx= 350 to 380 in step of 5
- UL-xxxM-108, xxx= 315 to 345 in step of 5
- UL-xxxM-96, xxx= 280 to 305 in step of 5
- UL-xxxM-156, xxx= 565 to 600 in steps of 5
- UL-xxxM-144, xxx= 525 to 550 in steps of 5
- UL-xxxM-132, xxx= 480 to 505 in steps of 5
- UL-xxxM-120, xxx= 435 to 460 in steps of 5
- UL-xxxM-108, xxx= 395 to 415 in steps of 5
- UL-xxxM-96, xxx= 350 to 370 in steps of 5

**Half cell 1500 V DC system voltage Single Glass modules:**

- UL-xxxM-144HV, xxx= 370 to 415 in step of 5
  - UL-xxxM-120HV, xxx= 305 to 345 in step of 5
  - UL-xxxM-108HV, xxx= 275 to 315 in step of 5
  - UL-xxxM-96HV, xxx= 245 to 275 in step of 5
  - UL-xxxM-144HV, xxx= 420 to 460 in step of 5
  - UL-xxxM-120HV, xxx= 350 to 380 in step of 5
  - UL-xxxM-108HV, xxx= 315 to 345 in step of 5
  - UL-xxxM-96HV, xxx= 280 to 305 in step of 5
  - UL-xxxM-156HV, xxx= 565 to 600 in steps of 5
  - UL-xxxM-144HV, xxx= 525 to 550 in steps of 5
  - UL-xxxM-132HV, xxx= 480 to 505 in steps of 5
  - UL-xxxM-120HV, xxx= 435 to 460 in steps of 5
  - UL-xxxM-108HV, xxx= 395 to 415 in steps of 5
  - UL-xxxM-96HV, xxx= 350 to 370 in steps of 5
- xxx is standing for rated output power at STC



# CERTIFICATE

No. Z2 083334 0048 Rev. 10

## Parameters:

Construction:	Framed, with Junction box, Cable and Connectors.
Fire Safety Class:	Class C according to UL790
Test Laboratory:	Yangzhou Opto-Electrical Products Testing Institute; No. 10 West Kaifa Road, Yangzhou 225009 Jiangsu, P. R. China
Safety Class:	Class II
Maximum System Voltage:	1000 V DC or 1500 V DC

## Tested according to:

IEC 61215-1:2016  
IEC 61215-1-1:2016  
IEC 61215-2:2016  
IEC 61730-1:2016  
IEC 61730-2:2016

# MONO HALF-CUT MODULE

## UL-405 | 410 | 415M-108HV

### 405W-415W 1500V **MBB 182mm cell**

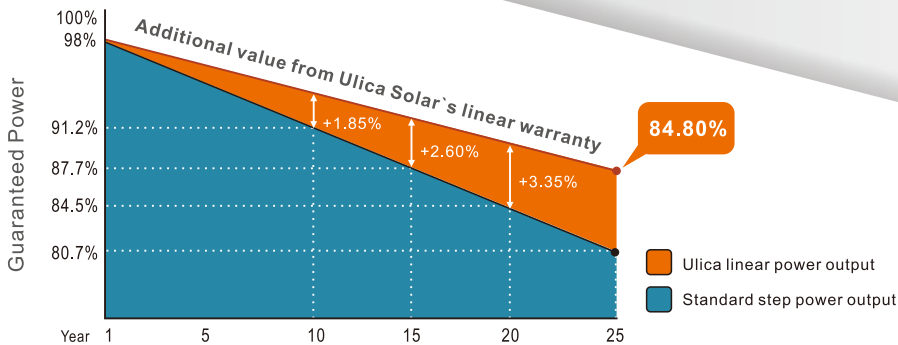
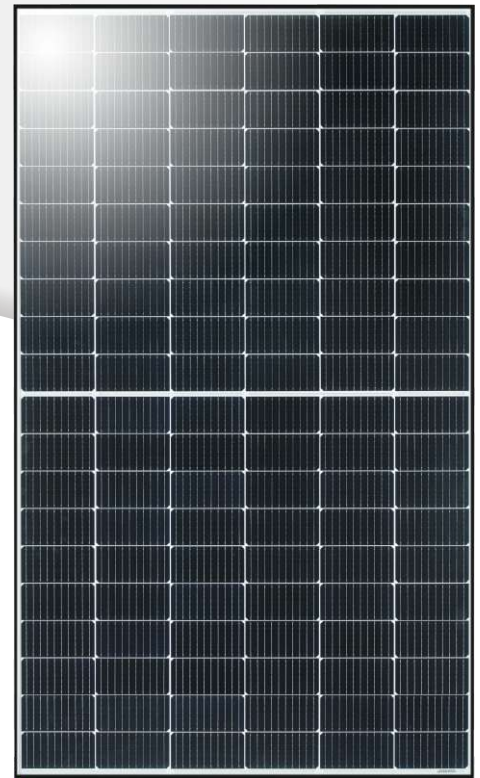

Global Tier 1 brand as announced by Bloomberg NEF



**Lower LCOE**  
Lower shading and resistive loss  
Lower temperature coefficient



**Outstanding mechanical load resistance**  
2400 Pa wind load, 5400 Pa snow load



**Anti-PID (potential induced degradation)**  
Passed anti-PID test under 85% damp heat, 85% relative humidity for 96 hours



**Great Durability against extreme conditions**  
Passed salt mist corrosion test, ammonia corrosion test, dust & sand test, fire test, all certified by TUV



**About Ulica Solar:** As member of Shanshan Group (stock code: 600884) which is TOP500 Enterprise in China, Ulica Solar is the leading manufacturer of solar cells and solar panels in China since 2005, and has been continuously listed as the Tier 1 PV Module Manufacturer from Q1 2020 by Bloomberg NEF, with the annual capacity of 1.2GW, and own investment projects of 300MW.

# MONO UL-405 | 410 | 415M-108HV



## ELECTRICAL PERFORMANCE

Electrical Parameters Standard Test Conditions

Module Type	UL-405M-108HV	UL-410M-108HV	UL-415M-108HV	
Power Output	P <sub>max</sub> W	405	410	415
Power Tolerance	ΔP <sub>max</sub> W		0/+5W	
Module Efficiency	η <sub>m</sub> %	20.74	21.0	21.25
Voltage at P <sub>max</sub>	V <sub>m</sub> V	31.3	31.4	31.5
Current at P <sub>max</sub>	I <sub>m</sub> A	12.94	13.06	13.17
Open-Circuit Voltage	V <sub>oc</sub> V	37.3	37.4	37.5
Short-Circuit Current	I <sub>sc</sub> A	13.69	13.81	13.93

STC:1000w/m<sup>2</sup> irradiance,25C module temperature,AM1.5

## THERMAL CHARACTERISTICS

Nominal Operating Cell Temperature	NOCT	°C	43±2
Temperature Coefficient of P <sub>max</sub>	γ	%/°C	-0.360
Temperature Coefficient of V <sub>oc</sub>	β <sub>voc</sub>	%/°C	-0.290
Temperature Coefficient of I <sub>sc</sub>	α <sub>isc</sub>	%/°C	+0.049

## OPERATING CONDITIONS

Max.System Voltage	DC1500V
Max.Series Fuse Rating	25A
Operating Temperature Range	-40°C~85°C
Max static snow load	5400Pa
Max static wind load	2400Pa
Application Class	A

## CONSTRUCTION MATERIALS

Front Cover(material/type/thickness)	low-iron tempered glass/3.2mm
Cell(quantity/material/type/dimension)	108/monocrystalline/ 182X91mm
Encapsulant(material)	ethylene vinyl acetate(EVA)
Frame(material/anodization color)	anodized aluminum alloy/silver or black
Junction Box(protection degree)	IP68
Cable(length/cross-sectional area)	400mm(or Customized Length)/4mm <sup>2</sup>
Plug Connector	MC4 compatible

## GENERAL CHARACTERISTICS

Dimension(L/W/H)	1722/1134/30mm
Weight	21.8kg

## PACKING CONFIGURATION

Pallet Size(L/W/H)	1762/1120/2550mm
Pallet Weight	1660kg
Pieces per Pallet	72pcs
Pieces per Container	936pcs

## INTERNATIONAL CERTIFICATES

IEC 61215, IEC 61730  
 ISO 9001: 2015(Quality management systems)  
 ISO 14001: 2015 (Environmental management systems)  
 OHSAS 18001: 2015 (Occupational health and safety)

## I-V CURVE

I-V characteristics at different irradiancies

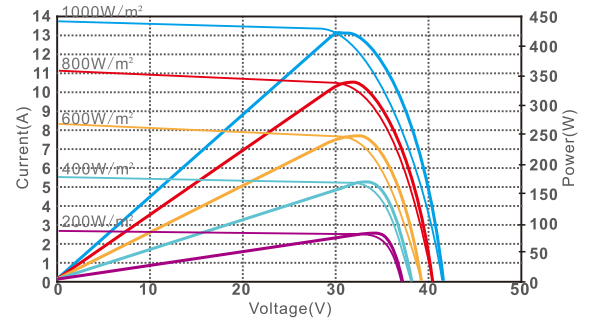

I-V characteristics at different temperature

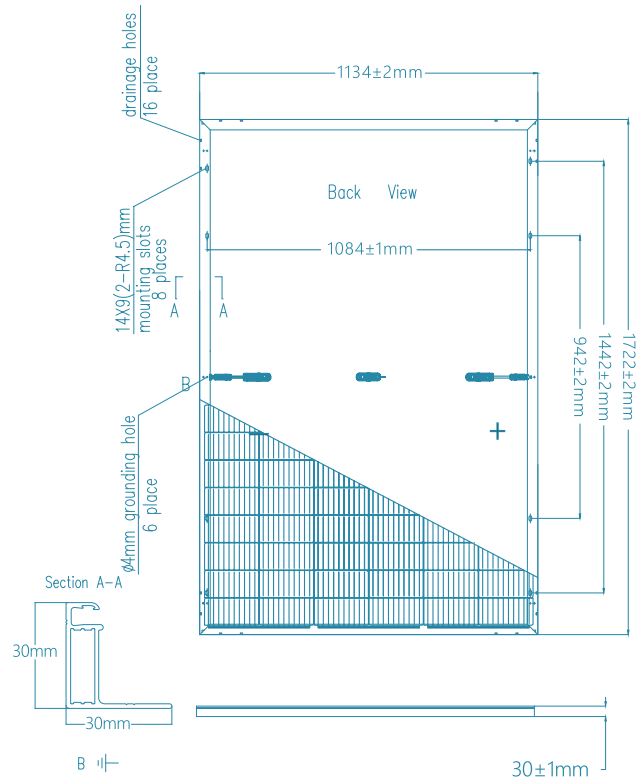
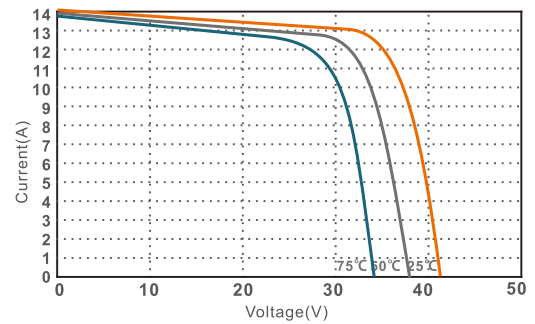

Please read the instruction entirely before handling, installing and operating Ullica Solar modules.

Due to continuous research and development, the specification is subject to change without prior notice.



Product Service

# Attestation of Conformity

No. N8A 083334 0063 Rev. 06

**Holder of Certificate:** **Ningbo Ulica Solar Co., Ltd.**  
NO.181-197, Shanshan Road  
Wangchun Industrial District  
315177 Ningbo  
PEOPLE'S REPUBLIC OF CHINA

**Product:** **Crystalline Silicon Terrestrial Photovoltaic (PV) Modules**  
**Mono-Crystalline Silicon Photovoltaic Module**

This Attestation of Conformity is issued on a voluntary basis according to the Low Voltage Directive 2014/35/EU relating to electrical equipment designed for use within certain voltage limits. It confirms that the listed equipment complies with the principal protection requirements of the directive and is based on the technical specifications applicable at the time of issuance. It refers only to the particular sample submitted for testing and certification. For details see: [www.tuvsud.com/ps-cert](http://www.tuvsud.com/ps-cert)

**Test report no.:** 704061806602-10

**Date,** 2021-09-17

( Zhulin Zhang )

Page 1 of 3

After preparation of the necessary technical documentation as well as the EU declaration of conformity the required CE marking can be affixed on the product. The declaration of conformity is issued under the sole responsibility of the manufacturer. Other relevant EU-directives have to be observed.



# Attestation of Conformity

No. N8A 083334 0063 Rev. 06

## Model(s):

### 1000 V DC system voltage Single Glass modules:

- UL-xxxM-72, xxx= 330 to 390 in step of 5
- UL-xxxM-60, xxx= 275 to 325 in step of 5
- UL-xxxM-54, xxx= 245 to 290 in step of 5
- UL-xxxM-48, xxx= 220 to 260 in step of 5
- UL-xxxM-24, xxx= 110 to 130 in step of 5

### 1500 V DC system voltage Single Glass modules:

- UL-xxxM-72HV, xxx= 330 to 390 in step of 5
- UL-xxxM-60HV, xxx= 275 to 325 in step of 5
- UL-xxxM-54HV, xxx= 245 to 290 in step of 5
- UL-xxxM-48HV, xxx= 220 to 260 in step of 5
- UL-xxxM-24HV, xxx= 110 to 130 in step of 5

### Half cell 1000 V DC system voltage Single Glass modules:

- UL-xxxM-144, xxx= 370 to 415 in step of 5
- UL-xxxM-120, xxx= 305 to 345 in step of 5
- UL-xxxM-108, xxx= 275 to 315 in step of 5
- UL-xxxM-96, xxx= 245 to 275 in step of 5
- UL-xxxM-144, xxx= 420 to 460 in step of 5
- UL-xxxM-120, xxx= 350 to 380 in step of 5
- UL-xxxM-108, xxx= 315 to 345 in step of 5
- UL-xxxM-96, xxx= 280 to 305 in step of 5
- UL-xxxM-156, xxx= 565 to 600 in steps of 5
- UL-xxxM-144, xxx= 525 to 550 in steps of 5
- UL-xxxM-132, xxx= 480 to 505 in steps of 5
- UL-xxxM-120, xxx= 435 to 460 in steps of 5
- UL-xxxM-108, xxx= 395 to 415 in steps of 5
- UL-xxxM-96, xxx= 350 to 370 in steps of 5

### Half cell 1500 V DC system voltage Single Glass modules:

- UL-xxxM-144HV, xxx= 370 to 415 in step of 5
  - UL-xxxM-120HV, xxx= 305 to 345 in step of 5
  - UL-xxxM-108HV, xxx= 275 to 315 in step of 5
  - UL-xxxM-96HV, xxx= 245 to 275 in step of 5
  - UL-xxxM-144HV, xxx= 420 to 460 in step of 5
  - UL-xxxM-120HV, xxx= 350 to 380 in step of 5
  - UL-xxxM-108HV, xxx= 315 to 345 in step of 5
  - UL-xxxM-96HV, xxx= 280 to 305 in step of 5
  - UL-xxxM-156HV, xxx= 565 to 600 in steps of 5
  - UL-xxxM-144HV, xxx= 525 to 550 in steps of 5
  - UL-xxxM-132HV, xxx= 480 to 505 in steps of 5
  - UL-xxxM-120HV, xxx= 435 to 460 in steps of 5
  - UL-xxxM-108HV, xxx= 395 to 415 in steps of 5
  - UL-xxxM-96HV, xxx= 350 to 370 in steps of 5
- xxx is standing for rated output power at STC



Product Service

# Attestation of Conformity

No. N8A 083334 0063 Rev. 06

<b>Parameters:</b>	Construction:	Framed, with Junction box, Cable and connectors.
	Test Laboratory:	Yangzhou Opto-Electrical Products Testing Institute No.10 West Kaifa Road, Yangzhou 225009 Jiangsu, P.R.China.
	Safety Class:	Class II
	Max. system voltage:	1000 V DC or 1500 V DC
	Fire Safety Class:	Class C according to UL790

<b>Tested according to:</b>	EN IEC 61730-1:2018
	EN IEC 61730-1:2018/AC:2018-06
	EN IEC 61730-2:2018
	EN IEC 61730-2:2018/AC:2018-06



## Installation Manual of Solar Module2022

**Note:**

- ✧ *Electrical and mechanical installation information will be introduced in this installation manual, so please read carefully and understand the information before before installing, operating or servicing the PV system.*
- ✧ *The Buyer shall not change the installation method by their own, any simplified installation method or different from this installation manual shall be checked with and confirmed by the Seller, otherwise the Seller will not be responsible for any quality issues caused by the unauthorized installation method.*
- ✧ *Failure to follow these instructions may result in bodily injury or damage to property. Keep these instructions!*
- ✧ *Working on a Pv system (installation, setup, maintenance, repairs) must be carried out by qualified and authorized persons.*

## Table of Contents

1. Introduction.....	- 3 -
2. Laws and Regulation .....	- 3 -
3. General Information.....	- 3 -
3.1 Modules identification .....	- 3 -
3.2 Junction box style and wiring method .....	- 5 -
3.3 Regular Safety .....	- 5 -
3.4 Electrical Performance Safety .....	- 6 -
3.5 Operation Safety .....	- 6 -
3.6 Fire Safety.....	- 7 -
3.7 Unload/Transportation .....	- 7 -
4. Installation Conditions.....	- 8 -
4.1 Installation Site and Working Environment .....	- 8 -
4.2 Selection of Tilt Angles .....	- 8 -
5. Mechanical Installation.....	- 9 -
5.1 Regular Requirements .....	- 9 -
5.2 Monofacial assembly mechanical installation .....	- 10 -
5.3 Bifacial module Mechanical Installation .....	- 16 -
6. Electrical installation .....	- 18 -
6.1 Electrical Performance.....	- 18 -
6.2 Cables and Wiring .....	- 19 -
6.3 Connector.....	- 20 -
6.4 Bypass diode.....	- 20 -
6.5 PID.....	- 20 -
7. Grounding .....	- 20 -
8. Operation and maintenance .....	- 21 -
8.1 Cleaning.....	- 21 -
8.2 Module Appearance Inspection .....	- 22 -
8.3 Inspection of Connectors and Cables .....	- 22 -
9. Release and execution.....	- 22 -

## **1. Introduction**

Electrical and mechanical installation information will be introduced in this installation manual, so please read and understand the information before installing Ulica's modules. In addition, this manual also contains some safety information that you shall be familiar with. All contents in this manual are intellectual properties of Ulica which originates from long term of technical exploration and experience accumulation of Ulica.

This installation manual does not entail any explicit or implicit quality warranty and does not stipulate on compensation schemes for losses, module damages or other costs caused by or related to module installation, operation, utilization and maintenance process. Ulica will not take any responsibility if patent rights or the third party rights are infringed by use of modules. Ulica reserves the rights for modifying product manual or installation manual without noticing in advance. It is recommended to visit our website regularly at [www.Ulica-solar.com](http://www.Ulica-solar.com) for the latest version of this installation manual. If customers fail to install modules as per requirements set forth in this manual, the limited warranty provided for customers will be invalid. In addition, suggestions in this manual are to improve safety of module installation, which are tested and proved by practices. Please provide this manual to PV system users for reference and advise on PPE(Personal Protective Equipment), operation and maintenance requirements and other suggestions..

## **2. Laws and Regulation**

The mechanical and electrical installation of photovoltaic modules shall be in accordance with applicable regulations, including electrical law, construction law and electrical connection requirements. These regulations vary from sites to sites, for example, building roof installation, vehicle applications, etc. Requirements may also vary depending on the installed system voltage, DC or AC. Please contact local authorities for specific terms.

## **3. General Information**

### **3.1 Modules identification**

Labels on the modules contain information below:

3.1.1. Nameplate: product type, rated power, rated current, rated voltage, open circuit voltage, short circuit current under testing conditions, certification indicator, maximum system voltage, etc.

3.1.2. Current classification label: Rated working current. (H indicates High, M indicates Medium, L indicates Low), this is optional.

3.1.3. Serial Number label: A unique serial number which is laminated inside the module permanently which can be found in the front of the module. There are another same serial numbers beside the module nameplate and side of aluminum frame.

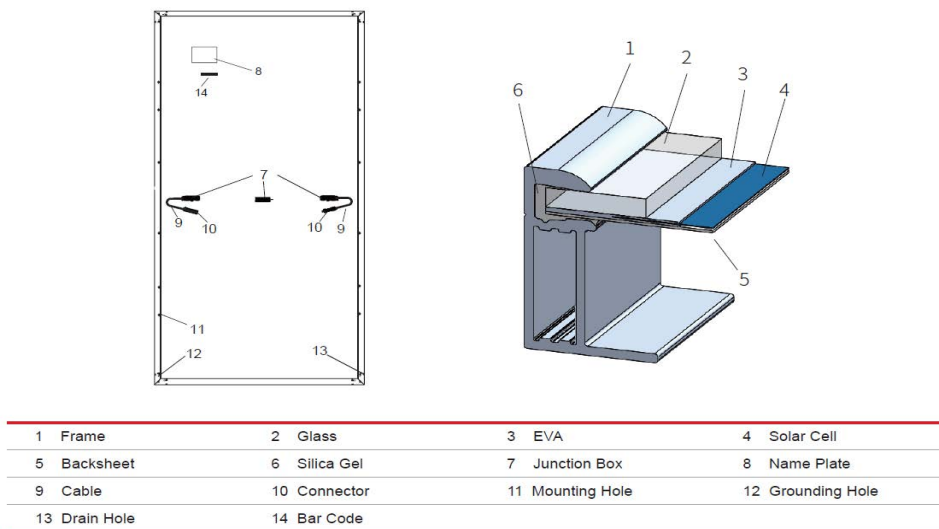

Figure 1 Regular modules Mechanical drawing

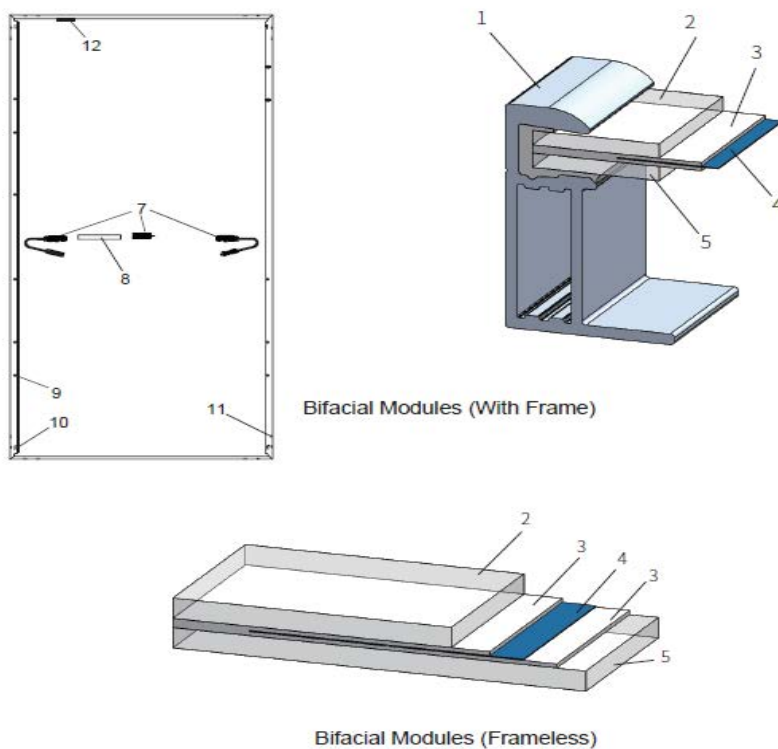

Figure 2 Regular Modules Mechanical Drawing

### 3.2 Junction box style and wiring method

Junction Box Location Icon	Recommended Wiring Method
	<p>Vertical Installation: Standard Cable length: (Note: An extension cord is required at the rotor head of the double row assembly and at the end of the single row.)</p> 
	<p>Horizontal Installation: 60 type PV module cable length <math>\geq 1.2\text{m}</math>, 72 type PV module cable length <math>\geq 1.4\text{m}</math>, 78 type PV module cable length <math>\geq 1.5\text{m}</math></p> 

Figure 3 Junction Box Style and Wiring Method

### 3.3 Regular Safety

3.3.1 The application level of Ulica Solar module is ClassII, which can be used in systems operating at  $> 50\text{ V DC}$  or  $>240\text{ W}$ , where general contact access is anticipated;

3.3.2 When the modules are for rooftop application, it is necessary to take the overall fire rating of the finished structure as well as operation and maintenance into account. The roofing PV system shall be installed after being evaluated by construction experts or engineers and with official analysis results for the entire structure. It shall be proved capable of supporting extra system bracket pressure, including PV module weight.

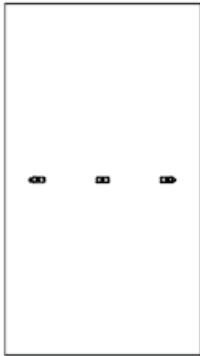
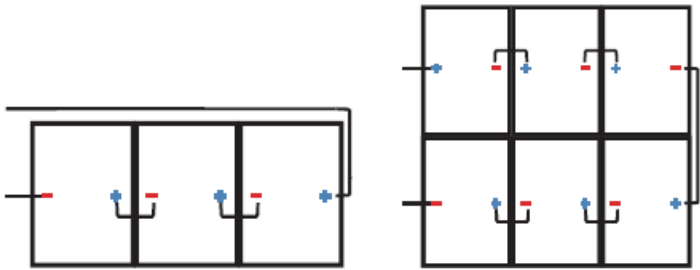
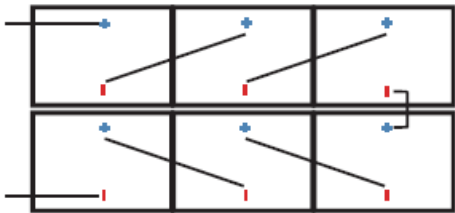
3.3.3 For your safety, please do not work on the roof without PPE(Personal Protective Equipment) which include but not limited to fall protection, ladder or stair and personal protective measures.

3.3.4 For your safety, please do not install or handle modules in unsafe conditions including but not limited to strong wind or gust, damp or sandy roofs.

3.3.5 Installing solar photovoltaic systems requires specialized skills and knowledge.

3.3.6 Installation should only be performed by qualified personnel.

3.3.7 Installers should assume all risks of injury that might occur during installation, including, but not limited to, the risk of electric shock.

3.3.8 One single module may generate more than  $30\text{V DC}$  when exposed to direct sunlight. Contact with a DC voltage of  $30\text{V}$  or more is potentially hazardous.

3.3.9 Do not disconnect under load.

3.3.10 Photovoltaic solar modules convert light energy to direct current electrical energy.

3.3.11 They are designed for outdoor use. Modules can be ground mounted, vehicles or boats. The proper design of support structures lies within the responsibility of the system designers and installers.

3.3.12 When installing the system, abide to all local, regional and national statutory regulations. Obtain a building permit if necessary.

3.3.13 The electrical characteristics are within  $\pm 10$  percent of the indicated values of  $I_{sc}$ ,  $V_{oc}$  and  $P_{max}$  under standard test conditions (irradiance of  $100 \text{ mW/cm}^2$ , AM 1.5 spectrum, and a cell temperature of  $25^\circ\text{C}$  ( $77^\circ\text{F}$ )).

3.3.14 Only use equipment, connectors, wiring and support frames suitable for solar electric systems.

### 3.4 Electrical Performance Safety

PV modules can produce DC current under illumination, any contact of the exposed metal of the modules connection wires may result in electrical shock or burn. Any contact of 30V or larger DC Voltage can be fatal.

In case of no connected load or external circuits, modules can still produce voltage. Please use insulation tools and wear rubber gloves when operating modules in the sunlight.

No switch is on the PV modules. Operating of PV modules can only be stopped when they are kept from sunlight or covered by hard board or UV-proof materials or when the angle of the modules facing sun are placed on smooth and flat surfaces.

To avoid electric arc or electric shock hazards, please do not break down electric connection in loaded conditions. Incorrect connections will also lead to electric arc or shock. Keep connectors dry and clean and make sure that they are in good operating condition. Do not insert other metals into the connectors or carry out electric connection by whatever means.

Snow, water or other reflective medium in surrounding environments that intensify light re-flection will increase output current and power. And module voltage and power will increase under low temperature condition.

If module glass or other sealing materials are damaged, please wear PPE(personal protective equipment) and then isolate modules from the circuit.

Do not operate when modules are wet unless you wear PPE(personal protective equipment). Please follow the cleaning requirements in this manual when cleaning modules.

Do not contact connectors with the following chemicals: Gasoline, White Flower oil, wood lock oil, Mold temperature oil, Engine oil (such as KV46), Grease (such as Molykote EM-50L), Lubricating oil, Rust-proof oil, Stamping oil, Diesel, Cooking oil, Acetone, alcohol, essential balm, Bone-setting liquid, Banana oil, release agent (such as Pelicoat S-6), adhesive and potting materials capable of generating oxime gas (such as KE200、CX-200、chemlok), TBP, cleaning agent etc.

### 3.5 Operation Safety



Figure 4 operation safety diagram of module

3.5.1 Open modules outer Package when installation.

3.5.2 Do not damage the package and do not drop packaged modules on the ground.

3.5.3 Do not exceed the indicated maximum layer limit on the packaging carton when piling modules up.

- 3.5.4 Put packaging carton in the ventilated, water-proof and dry places before unpacking modules.
- 3.5.5 Follow unpacking instructions when Opening packaging carton.
- 3.5.6 Carrying modules with the junction box or wires are strictly forbidden.
- 3.5.7 Do not stand or walk on modules.
- 3.5.8 To avoid glass to be damaged, heavy objects are not allowed on modules.
- 3.5.9 Be careful when placing modules at corners in particular.
- 3.5.10 Do not try to dismantle the module or remove nameplate or parts of modules.
- 3.5.11 Do not paint or apply any other adhesive on modules.
- 3.5.12 Do not damage or scratch backsheet of modules.
- 3.5.13 Do not drill holes on the frame of module, which may reduce frame loading capacity and lead to frame corrosion and invalidation of the limited warranty provided for customers.
- 3.5.14 Do not scratch anodic coating of aluminum alloy frame except for grounding connection. Scratch may lead to frame corrosion and reduce frame loading capacity and long-term reliability.
- 3.5.15 Do not repair problematic modules on your own.

### 3.6 Fire Safety

Please refer to local laws and regulations before installing modules and abide by requirements on building fire protection. According to the corresponding certification standards, the fire rating of Ulica modules is Class C. The roof should be coated by a layer of fireproof materials with suitable fire protection rating for roofing installation and make sure that the back sheet and the mounting surface are fully ventilated. Different roof structures and installation modes will affect fireproof performance of buildings. Improper installation may lead to the risk of fire.

To guarantee roof fire rating, the distance between module frame and roof surface must be  $\geq 10\text{cm}$ . (4in) Adopt proper module accessories such as fuse, circuit breaker and grounding connector according to local regulations.

Please do not apply modules in where exposed inflammable gases are nearby.

### 3.7 Unload/Transportation

Precautions and general safety rules:

3.7.1 The modules should be stored in the original Ulica package before installation. Protect the package from damage. Unpack the modules as per the recommended unpacking procedures. The whole process of unpacking, transport and storing should be handled with care.

3.7.2 Do not stand, climb, walk or jump on unpacked pallets of modules.

3.7.3 Before installation, ensure that all modules and electrical contacts are clean and dry.

If the modules are required to be stored temporarily, they should be stored under dry and ventilated conditions.

3.7.4 Unpacking must be carried out by two or more persons at the same time. It is forbidden to use the wires or junction boxes of the modules to carry the modules. Handling the modules requires two or more people with non-slip gloves; Do NOT handle the modules over-head or stack the modules.

3.7.5 Do not put the modules in a place that is not supported or stable.

3.7.6 Do not allow the modules to come in contact with sharp-pointed objectives to prevent them from scratches, avoiding a direct impact on the safety of modules.

3.7.7 Do not remove the original packaging if the modules require long-distance transport or long-term storage.

3.7.8 The finished package can be transported by land, sea or air. During transport, make sure that the package is fixed with packing straps securely to the shipping platform without movement.

3.7.9 Transport: Do not stack more than two layers on truck.

3.7.10 Only one layer stacking is only allowed for small truck. Make sure that the package is fixed with packing straps securely to the shipping platform without movement.

3.7.11 Only one layer stacking is only allowed for transport at the project site.

## **4. Installation Conditions**

### **4.1 Installation Site and Working Environment**

4.1.1 The modules cannot be used in space.

4.1.2 Do not manually focus sunlight with mirrors or magnifying glass onto modules.

4.1.3 Ulica modules shall be installed on proper buildings or other appropriate places (such as ground, garage, building outer wall, roof, PV tracking system) but shall not be installed on any vehicles.

4.1.4 Do not install modules at places that are possible to be flooded.

4.1.5 Ulica suggests that modules be installed in the working environment with the temperature of  $-20^{\circ}\text{C}$  to  $50^{\circ}\text{C}$  of which is the monthly average highest and lowest temperature of the installation sites. The extreme working environment temperature for modules is  $-40^{\circ}\text{C}$  to  $85^{\circ}\text{C}$ .

4.1.6 Make sure that installed modules do not suffer wind or snow pressure that exceeds the permissible maximum load limit.

4.1.7 Modules shall be installed in places free from shadows throughout the year. Make sure there are no light-blocking obstacles in the installation sites.

4.1.8 Carry out lightning protection for modules installed in places with frequent lightning and thunder.

4.1.9 Do not install modules in places with possible inflammable gases.

4.1.10 Modules cannot be used in environments with too much hails, snows, flue gas, air pollution and soot or in places with strong corrosive substances such as salt, salt mist, saline, active chemical steam, acid rain, or other substances corroding modules, affecting modules' safety or performance.

4.1.11 Please take protective measures to ensure reliable and safe installation of modules in severe environments such as heavy snow, cold and strong wind or islands close to water and salt mist or deserts.

4.1.12 Ulica modules passed the IEC61701 salt spray corrosion test, but the corrosion may still occur on where the modules frame is connected to the bracket or where the grounding is connected. In case Ulica modules are installed 50m –500m away from the ocean side, stainless steel or aluminum materials are need to be used to contact the PV modules, and the connection point should be protected with anti-corrosion measures. If it needs to be installed within 50m of the sea or on the sea or beach, please contact the sales representative of Ulica.

### **4.2 Selection of Tilt Angles**

Tilt angle of modules: Included angle between module surface and horizontal surface; the module will obtain the maximum power output in direct facing of sunlight.



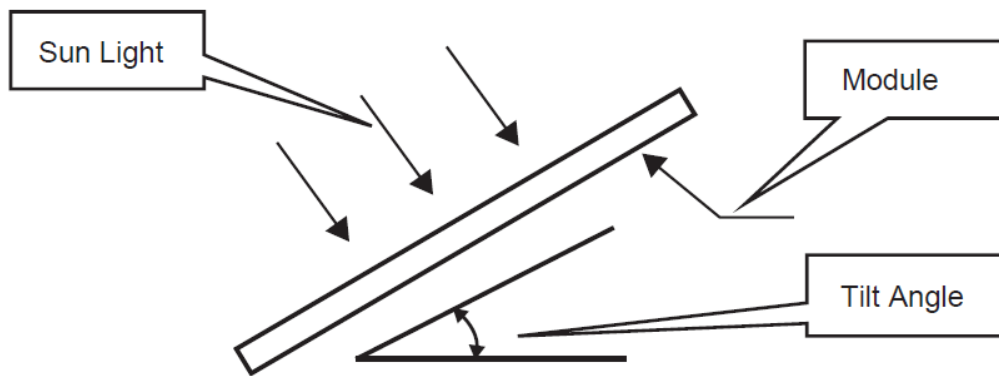

Figure 5 Schematic diagram of component inclination

Modules are preferred to be south-facing in the north hemisphere and north-facing in the south hemisphere. Please refer to standard modules installation guideline or suggestions from experienced PV module installer, for the specific installation angle.

Ulica suggests that tilt angle of module installation be no less than  $10^\circ$ , so module surface dust can be washed away easily by rainfall and frequency of cleaning can be reduced. In that case, the PV's generation will difficult to guarantee. If the tilt angle of module installation less than  $5^\circ$ , some cells will cause hot spots caused by dust and pollutants and reduce power generation, even with regular maintenance, the power generation may not meet the expectations. The tilt angle of module installation less than  $1^\circ$  is strictly prohibited, if not the warranty will be invalid.

And it is easy for ponding to flow away and avoid water mark on the glass due to long time of water ponding which may further affect module appearance and performance.

Ulica modules connected in string should be installed with the same orientation and tilt angle. Different orientations and tilt angles may result in different received solar irradiation and output power loss. In order to achieve the maximum annual generating capacity, the optimal orientation and inclination of PV modules in the installed area should be selected to ensure that sunlight can still reach to modules even on the shortest day of the year.

If Ulica modules are used in off-grid System, the tilt angle should be calculated based on seasons and irradiation to maximize the output power. If the modules output power meets the acquired load under the period of the worst irradiation in the year, the modules should be able to meet the load of the whole year. If the Ulica modules are used in grid-connected system, the tilt angle should be calculated based on the principle to maximize the yearly output power.

## 5. Mechanical Installation

### 5.1 Regular Requirements

5.1.1 Make sure that module installation mode and bracket system can meet the expected load, which is requisite assurance that the bracket installer must provide. Installation bracket system shall be tested and inspected by the third party testing institution with static mechanical analysis capacity in accordance with local national standards or international standards.

5.1.2 Module bracket shall be made from durable, corrosion resistant, UV-proof materials.

5.1.3 Modules shall be fixed on the bracket solidly.

5.1.4 Use higher brackets in places with heavy snow accumulation so the lowest point of modules will not be shadowed by snow for a long time. In addition, make the lowest point of modules high enough so as to avoid shading of vegetation and woods or reduce damage of sands and stones.

5.1.5 If modules are installed on brackets parallel to the roof or wall, the minimum gap between the module frame and the roof/wall shall be 10cm for air ventilation in case of module wire damage.

5.1.6 Make sure the building is suitable for installation before installing modules on roof. Moreover, seal properly to prevent leakage.

5.1.7 The module frames can appear thermal expansion and cold contraction so the frame interval between two adjoining modules shall be no less than 10mm.

5.1.8 Make sure that backsheet of modules will not be in contact with bracket or building structures that can pierce into the inside of the modules, especially when the module surface is imposed by pressure.

5.1.9 Maximum static load of the PV module is down force 5400pa and uplift force 2400pa, which can vary from different mounting methods of the modules (please refer to the following installation guidance), the described load in this manual is for the test load.

5.1.10 Note: on the basis of IEC61215 - 2016 installation requirements, when computing the corresponding maximum design load, need to consider the safety factor of 1.5 times.

5.1.11 Modules can be installed horizontally or vertically. When installing the modules, be cautious not to block the drain hole of the frame.

## 5.2 Monofacial assembly mechanical installation

Module and bracket system connection can be realized by mounting holes, clamps or embedded systems. Installation shall follow the demonstration and suggestions below. If installation mode is different, please consult Ulica and obtain approval. Otherwise, modules may be damaged and limited warranty will be invalid.

### 5.2.1 Bolts Mounting

Apply bolts to fix modules on the bracket through mounting holes on the back frame. See details in Figure6.

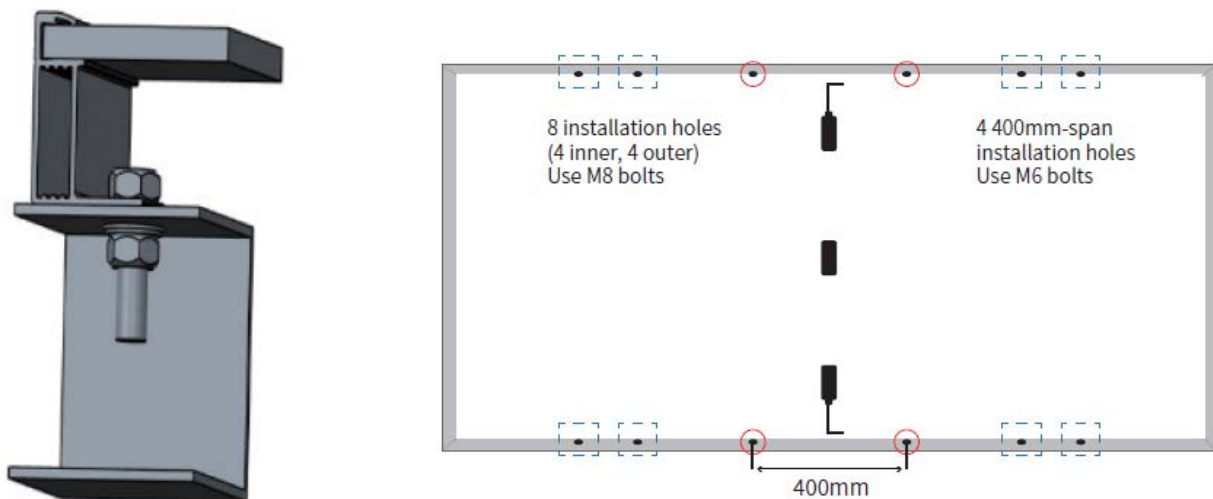
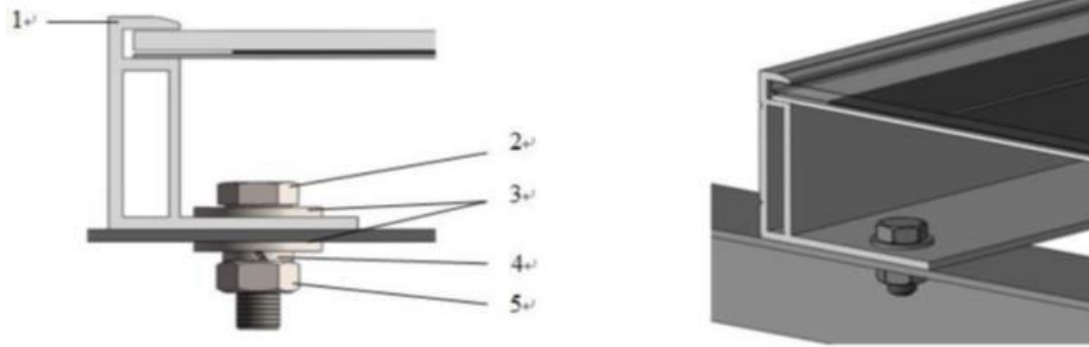

Figure 6 Schematic diagram1 of monofacial module with bolt Installation



- 1. Aluminum alloy frame    2. M8 stainless bolt    3. Flat stainless washer
- 4. Spring stainless washer
- 5. HEX stainless nut

Figure7 Schematic diagram2 of monofacial module with bolt Installation

Recommended accessories are as below :

Accessories	Model	Material	Note
Bolt	M8 (full thread recommended)	M6 (full thread recommended)	Accessories material selection should be based on application environment.
Washer	2*8	2*6 (6.4*18-1.6 ISO 7093)	
Spring Washer	8	6	
Nut	M8	M6	

Table 2 Recommended materials of module with bolt Installation

Suggestion:

- (1) M8 bolt tightening torque range: 14N•m-18N•m; M6 bolt tightening torque range: 8N•m-12N•m;
- (2) When using Ulica 30mm (30H) height frame module, it is recommended to select  $L \leq 20\text{mm}$  length fasteners. (If there is a special model, consult Ulica customer service).

### 5.2.2 Clamp Mounting

The module can be mounted by a dedicated clamp, as shown in Figure 8.

Under no circumstances should the clamp touch the glass or deform the frame. The interface of the clamp to the front of the frame must be smooth and flat to prevent frame or other components from being damaged.

Make sure no shadowing effect of the fixture.

The drain hole cannot be blocked by the fixture.

For framed PV module, the clamp must maintain an overlap of 8-11 mm with the frame of the module (you can change the cross section of the clamp if the module is securely installed). For frameless PV module, the clamp must maintain an overlap of 15 mm at maximum with the module.

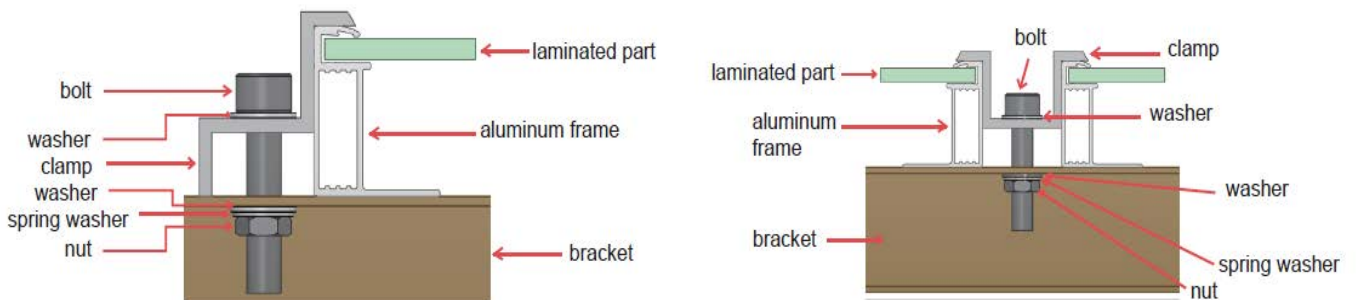

Figure 8 Clamp Installation of Monofacial Module

**5.2.3 Installation and Mechanical Load of Monofacial Module**

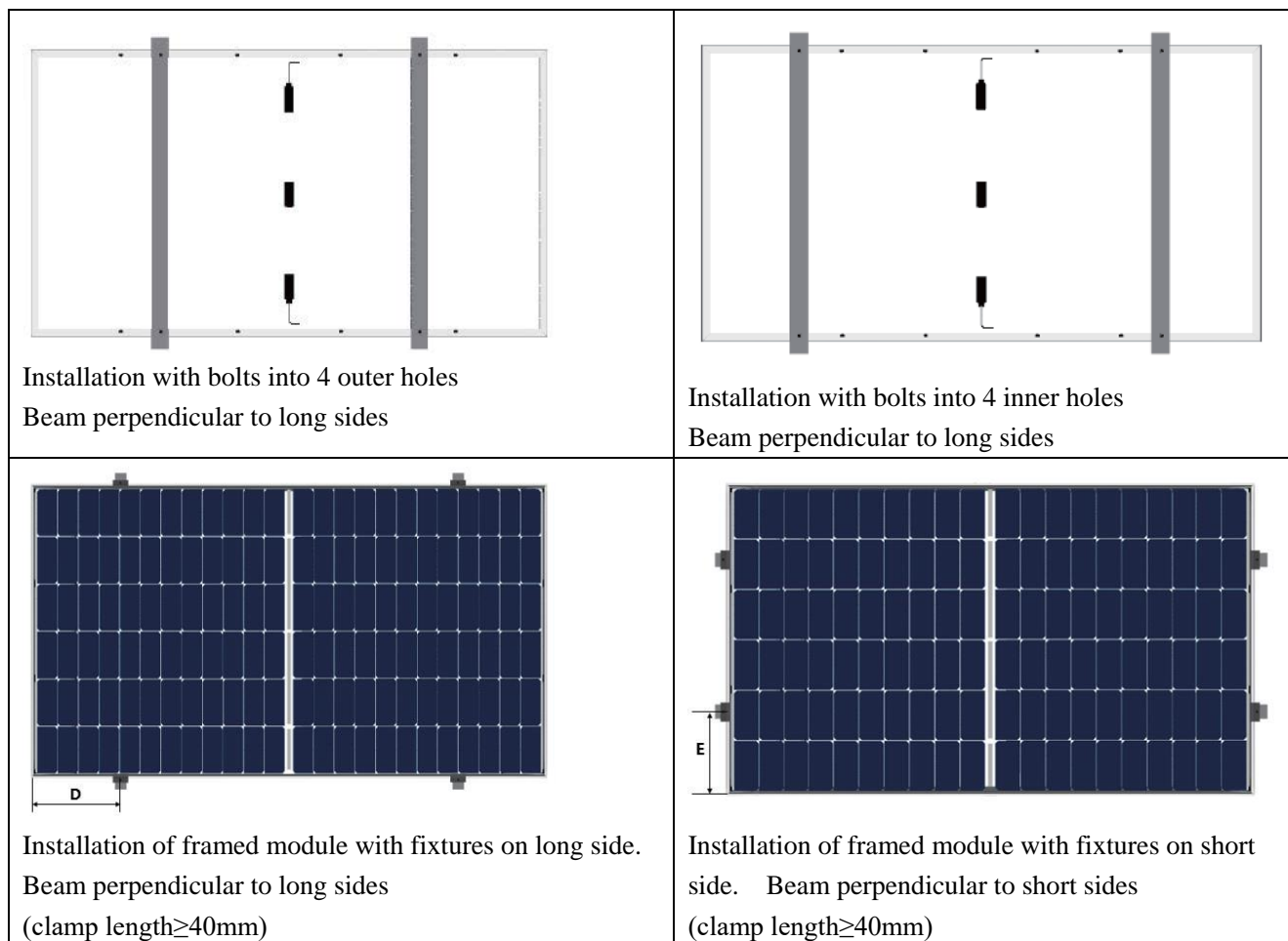

Figure 9 Monofacial Module Installation Annex

**Monofacial Modules model:**

Module type	Cell type	Cell quantity	Dimensions (mm)	Length of cable (mm) positive/ negative	Flame Dimensions (mm)
UL-xxx P-120 (156)	156*156	6*10*2	1685*992*35	400/300	35*35
UL-xxx M-120 (158)	158*158	6*10*2	1705*1004*35	400/300	35*35
UL-xxx M-120 (166)	166*166	6*10*2	1755*1038*30	400/300	30*30
UL-xxx M-108 (182)	182*182	6*9*2	1722*1134*30	400/300	30*30
UL-xxx M-132 (182)	182*182	6*11*2	2094*1134*35	400/300	35*35
UL-xxx M-144 (166)	166*166	6*12*2	2094*1038*35	400/300	35*35
UL-xxx M-144 (182)	182*182	6*12*2	2279*1134*35	400/300	35*35

Table 3 Ulica's Monofacial Modules



These installation mode are Ulica's recommended installation method.

Load Capacities of Framed Monofacial modules:

Installation Method  Module Type	Installation with bolts		Installation with fixtures		
	4 outer holes (beam perpendicular to long sides)	4 inner holes (beam perpendicular to long sides)	$1/4L-50 \leq D \leq 1/4L+50$ (beam perpendicular to long sides)	$350 \leq D \leq 450$ (beam perpendicular to long sides)	$150 \leq E \leq 250$ ( beam perpendicular to short sides )
<b>UL-xxx P-120 (156)</b>	Down force load $\leq 2400\text{Pa}$ , Uplift load $\leq 2400\text{Pa}$	Down force load $\leq 5400\text{Pa}$ , Uplift load $\leq 2400\text{Pa}$	Down force load $\leq 5400\text{Pa}$ , Uplift load $\leq 2400\text{Pa}$	Down force load $\leq 5400\text{Pa}$ , Uplift load $\leq 2400\text{Pa}$	Down force load $\leq 2400\text{Pa}$ , Uplift load $\leq 2400\text{Pa}$
<b>UL-xxx M-120 (158)</b>	Down force load $\leq 2400\text{Pa}$ , Uplift load $\leq 2400\text{Pa}$	Down force load $\leq 5400\text{Pa}$ , Uplift load $\leq 2400\text{Pa}$	Down force load $\leq 5400\text{Pa}$ , Uplift load $\leq 2400\text{Pa}$	Down force load $\leq 5400\text{Pa}$ , Uplift load $\leq 2400\text{Pa}$	Down force load $\leq 2400\text{Pa}$ , Uplift load $\leq 2400\text{Pa}$
<b>UL-xxx M-120 (166)</b>	Down force load $\leq 2400\text{Pa}$ , Uplift load $\leq 2400\text{Pa}$	Down force load $\leq 5400\text{Pa}$ , Uplift load $\leq 2400\text{Pa}$	Down force load $\leq 5400\text{Pa}$ , Uplift load $\leq 2400\text{Pa}$	Down force load $\leq 3600\text{Pa}$ , Uplift load $\leq 2400\text{Pa}$	Down force load $\leq 2400\text{Pa}$ , Uplift load $\leq 2400\text{Pa}$
<b>UL-xxx M-108 (182)</b>	Down force load $\leq 2400\text{Pa}$ , Uplift load $\leq 2400\text{Pa}$	Down force load $\leq 5400\text{Pa}$ , Uplift load $\leq 2400\text{Pa}$	Down force load $\leq 5400\text{Pa}$ , Uplift load $\leq 2400\text{Pa}$	Down force load $\leq 3600\text{Pa}$ , Uplift load $\leq 2400\text{Pa}$	Down force load $\leq 2400\text{Pa}$ , Uplift load $\leq 2400\text{Pa}$
<b>UL-xxx M-132 (182)</b>	Down force load $\leq 2400\text{Pa}$ , Uplift load $\leq 2400\text{Pa}$	Down force load $\leq 5400\text{Pa}$ , Uplift load $\leq 2400\text{Pa}$	Down force load $\leq 5400\text{Pa}$ , Uplift load $\leq 2400\text{Pa}$	Down force load $\leq 3600\text{Pa}$ , Uplift load $\leq 2400\text{Pa}$	Down force load $\leq 2400\text{Pa}$ , Uplift load $\leq 2400\text{Pa}$
<b>UL-xxx M-144 (166)</b>	Down force load $\leq 2400\text{Pa}$ , Uplift load $\leq 2400\text{Pa}$	Down force load $\leq 5400\text{Pa}$ , Uplift load $\leq 2400\text{Pa}$	Down force load $\leq 5400\text{Pa}$ , Uplift load $\leq 2400\text{Pa}$	Down force load $\leq 3600\text{Pa}$ , Uplift load $\leq 2400\text{Pa}$	Down force load $\leq 2400\text{Pa}$ , Uplift load $\leq 2400\text{Pa}$
<b>UL-xxx M-144 (182)</b>	Down force load $\leq 2400\text{Pa}$ , Uplift load $\leq 2400\text{Pa}$	Down force load $\leq 5400\text{Pa}$ , Uplift load $\leq 2400\text{Pa}$	Down force load $\leq 5400\text{Pa}$ , Uplift load $\leq 2400\text{Pa}$	Down force load $\leq 3600\text{Pa}$ , Uplift load $\leq 2400\text{Pa}$	Down force load $\leq 2400\text{Pa}$ , Uplift load $\leq 2400\text{Pa}$

Table 4 Down force load and Uplift load with different Installation mode

The following installation methods and mechanical loads have been verified by the Ulica Solar's Laboratory for PV Science and Technology. The following installation methods is Simple installation mode, these installation mode are not Ulica's recommended installation method.

 <p>Use 4 clamps on the short side. Mounting rails run perpendicular to the long side frame. ( fixture length <math>\geq 40\text{mm}</math> , <math>A=20\sim 200\text{mm}</math> )</p>	 <p>Use 4 clamps on the short side. No mounting rails ( fixture length <math>\geq 40\text{mm}</math> , <math>A=20\sim 200\text{mm}</math> )</p>
---	---

**Load capacities of framed Monofacial modules:**

Installation Method	Use 4 clamps on the short side. Mounting rails run perpendicular to the long side frame. ( fixture length $\geq$ 40mm , A=20~200mm )	Use 4 clamps on the short side. No mounting rails ( fixture length $\geq$ 40mm , A=20~200mm )
Module Type		
UL-xxx P-120 (156)	Down force load $\leq$ 1800Pa, Uplift load $\leq$ 1800Pa	Down force load $\leq$ 1800Pa, Uplift load $\leq$ 1800Pa
UL-xxx M-120 (158)	Down force load $\leq$ 1800Pa, Uplift load $\leq$ 1800Pa	Down force load $\leq$ 1800Pa, Uplift load $\leq$ 1800Pa
UL-xxx M-120 (166)	Down force load $\leq$ 1200Pa, Uplift load $\leq$ 1200Pa	Down force load $\leq$ 1200Pa, Uplift load $\leq$ 1200Pa
UL-xxx M-108 (182)	Down force load $\leq$ 1200Pa, Uplift load $\leq$ 1200Pa	Down force load $\leq$ 1200Pa, Uplift load $\leq$ 1200Pa
UL-xxx M-132 (182)	Down force load $\leq$ 1200Pa, Uplift load $\leq$ 1200Pa	Down force load $\leq$ 1200Pa, Uplift load $\leq$ 1200Pa
UL-xxx M-144 (166)	Down force load $\leq$ 1200Pa, Uplift load $\leq$ 1200Pa	Down force load $\leq$ 1200Pa, Uplift load $\leq$ 1200Pa
UL-xxx M-144 (182)	Down force load $\leq$ 1200Pa, Uplift load $\leq$ 1200Pa	Down force load $\leq$ 1200Pa, Uplift load $\leq$ 1200Pa

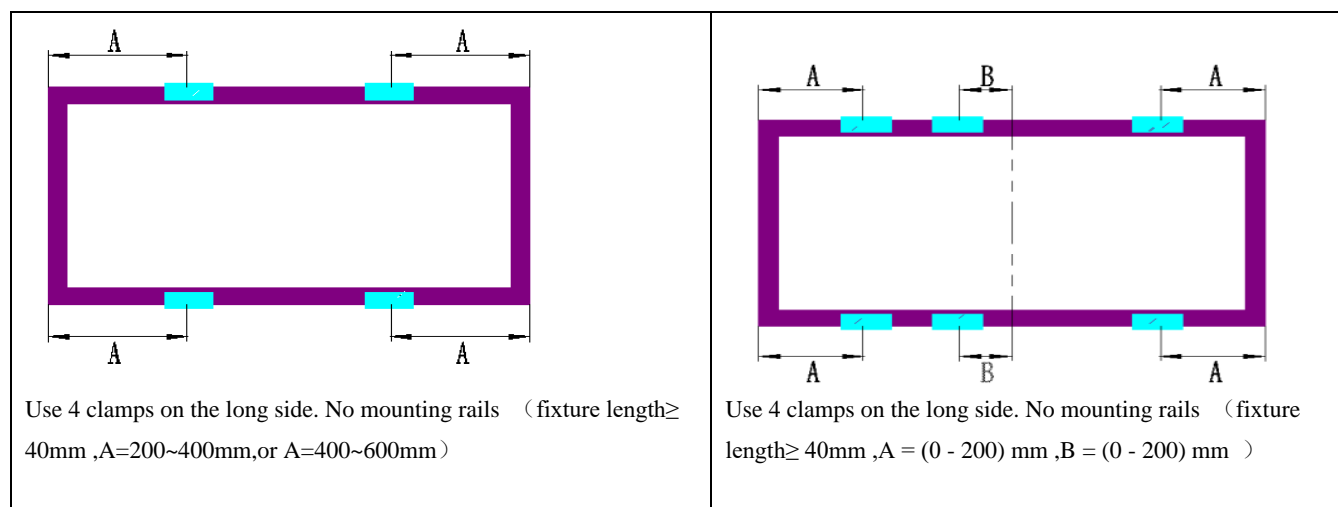

**Load capacities of framed Monofacial modules:**

Installation Method	Use 4 clamps on the long side. No mounting rails ( fixture length $\geq$ 40mm ,A=200~400mm,	Use 4 clamps on the long side. No mounting rails ( fixture length $\geq$ 40mm ,A = ( 0 - 200 ) mm ,B = ( 0 - 200 ) mm )
Module Type		
UL-xxx P-120 (156)	Down force load $\leq$ 3600Pa, Uplift load $\leq$ 2400Pa	Down force load $\leq$ 3600Pa, Uplift load $\leq$ 2400Pa
UL-xxx M-120 (158)	Down force load $\leq$ 3600Pa, Uplift load $\leq$ 2400Pa	Down force load $\leq$ 3600Pa, Uplift load $\leq$ 2400Pa
Installation Method	Use 4 clamps on the long side. No mounting rails ( fixture length $\geq$ 40mm ,A=400~600mm,	Use 4 clamps on the long side. No mounting rails ( fixture length $\geq$ 40mm ,A = ( 0 - 200 ) mm ,B = ( 0 - 200 ) mm )
Module Type		
UL-xxx M-120 (166)	Down force load $\leq$ 1800Pa, Uplift load $\leq$ 1800Pa	Down force load $\leq$ 1800Pa, Uplift load $\leq$ 2400Pa
UL-xxx M-108 (182)	Down force load $\leq$ 1800Pa, Uplift load $\leq$ 1800Pa	Down force load $\leq$ 1800Pa, Uplift load $\leq$ 2400Pa
UL-xxx M-132 (182)	Down force load $\leq$ 1800Pa, Uplift load $\leq$ 1800Pa	Down force load $\leq$ 1800Pa, Uplift load $\leq$ 2400Pa
UL-xxx M-144 (166)	Down force load $\leq$ 1800Pa, Uplift load $\leq$ 1800Pa	Down force load $\leq$ 1800Pa, Uplift load $\leq$ 2400Pa
UL-xxx M-144 (182)	Down force load $\leq$ 1800Pa, Uplift load $\leq$ 1800Pa	Down force load $\leq$ 1800Pa, Uplift load $\leq$ 2400Pa

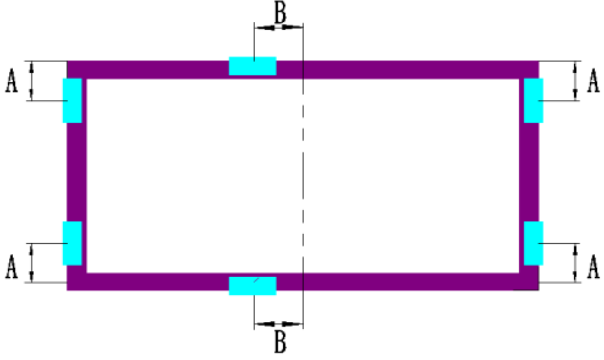

Use 4 clamps on the short side and 2 clamps on the long side.  
No mounting rails. ( fixture length  $\geq 40\text{mm}$ ,  $A = (0 - 200)\text{ mm}$ ,  $B = (0 - 200)\text{ mm}$  )

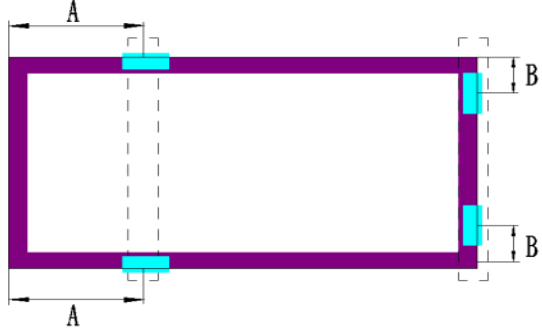

Use 2 clamps on the short side and 2 clamps on the long side.  
Mounting rails run perpendicular to the long side frame. ( fixture length  $\geq 40\text{mm}$ ,  $A = (250 - 450)\text{ mm}$ ,  $B = (100 - 250)\text{ mm}$  )

Installation Method	Use 4 clamps on the short side and 2 clamps on the long side. No mounting rails. ( fixture length $\geq 40\text{mm}$ , $A = (0 - 200)\text{ mm}$ , $B = (0 - 200)\text{ mm}$ )	Use 2 clamps on the short side and 2 clamps on the long side. Mounting rails run perpendicular to the long side frame. ( fixture length $\geq 40\text{mm}$ , $A = (250 - 450)\text{ mm}$ , $B = (100 - 250)\text{ mm}$ )
Module Type		
UL-xxx P-120 (156)	Down force load $\leq 3000\text{Pa}$ , Uplift load $\leq 2400\text{Pa}$	Down force load $\leq 2400\text{Pa}$ , Uplift load $\leq 1800\text{Pa}$
UL-xxx M-120 (158)	Down force load $\leq 3000\text{Pa}$ , Uplift load $\leq 2400\text{Pa}$	Down force load $\leq 2400\text{Pa}$ , Uplift load $\leq 1800\text{Pa}$
Installation Method	Use 4 clamps on the short side and 2 clamps on the long side. No mounting rails. ( fixture length $\geq 40\text{mm}$ , $A = (0 - 200)\text{ mm}$ , $B = (0 - 200)\text{ mm}$ )	Use 2 clamps on the short side and 2 clamps on the long side. Mounting rails run perpendicular to the long side frame. ( fixture length $\geq 40\text{mm}$ , $A = (250 - 450)\text{ mm}$ , $B = (100 - 250)\text{ mm}$ )
Module Type		
UL-xxx M-120 (166)	Down force load $\leq 1800\text{Pa}$ , Uplift load $\leq 1800\text{Pa}$	Down force load $\leq 1200\text{Pa}$ , Uplift load $\leq 1200\text{Pa}$
UL-xxx M-108 (182)	Down force load $\leq 1800\text{Pa}$ , Uplift load $\leq 1800\text{Pa}$	Down force load $\leq 1800\text{Pa}$ , Uplift load $\leq 1800\text{Pa}$
UL-xxx M-132 (182)	Down force load $\leq 1800\text{Pa}$ , Uplift load $\leq 1800\text{Pa}$	Down force load $\leq 1800\text{Pa}$ , Uplift load $\leq 1800\text{Pa}$
UL-xxx M-144 (166)	Down force load $\leq 1800\text{Pa}$ , Uplift load $\leq 1800\text{Pa}$	Down force load $\leq 1800\text{Pa}$ , Uplift load $\leq 1800\text{Pa}$
UL-xxx M-144 (182)	Down force load $\leq 1800\text{Pa}$ , Uplift load $\leq 1800\text{Pa}$	Down force load $\leq 1800\text{Pa}$ , Uplift load $\leq 1800\text{Pa}$



Slide-in rails on the short side. No fixture. Mounting rails run perpendicular to the long side

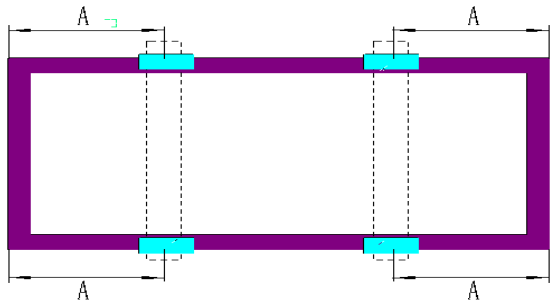

Use 4 clamps on the long side. Mounting rails run perpendicular to the long side frame. ( fixture length  $\geq 40\text{mm}$  )

Installation Method	Slide-in rails on the short side. No fixture. Mounting rails run perpendicular to the long side	Use 4 clamps on the long side. Mounting rails run perpendicular to the long side frame. ( fixture length $\geq 40\text{mm}$ )
Module Type		
UL-xxx P-120 (156)	Down force load $\leq 2400\text{Pa}$ , Uplift load $\leq 2000\text{Pa}$	Down force load $\leq 5400\text{Pa}$ , Uplift load $\leq 2400\text{Pa}$
UL-xxx M-120 (158)	Down force load $\leq 2400\text{Pa}$ , Uplift load $\leq 2000\text{Pa}$	Down force load $\leq 5400\text{Pa}$ , Uplift load $\leq 2400\text{Pa}$

Installation Method	Slide-in rails on the short side. No fixture. Mounting rails run perpendicular to the long side	Use 4 clamps on the long side. Mounting rails run perpendicular to the long side frame. (fixture length $\geq 40\text{mm}$ )
Module Type		
UL-xxx M-120 (166)	Down force load $\leq 1000\text{Pa}$ , Uplift load $\leq 1000\text{Pa}$	Down force load $\leq 5400\text{Pa}$ , Uplift load $\leq 2400\text{Pa}$
UL-xxx M-108 (182)	Down force load $\leq 1000\text{Pa}$ , Uplift load $\leq 1000\text{Pa}$	Down force load $\leq 5400\text{Pa}$ , Uplift load $\leq 2400\text{Pa}$
UL-xxx M-132 (182)	Down force load $\leq 1000\text{Pa}$ , Uplift load $\leq 1000\text{Pa}$	Down force load $\leq 5400\text{Pa}$ , Uplift load $\leq 2400\text{Pa}$
UL-xxx M-144 (166)	Down force load $\leq 1000\text{Pa}$ , Uplift load $\leq 1000\text{Pa}$	Down force load $\leq 5400\text{Pa}$ , Uplift load $\leq 2400\text{Pa}$
UL-xxx M-144 (182)	Down force load $\leq 1000\text{Pa}$ , Uplift load $\leq 1000\text{Pa}$	Down force load $\leq 5400\text{Pa}$ , Uplift load $\leq 2400\text{Pa}$

### 5.3 Bifacial module Mechanical Installation

Modules and mounting system can be connected by bolts, clamps or embedded systems. Installation shall follow the demonstration and suggestions below. If installation mode is different, please consult Ulica and obtain approval. Otherwise, modules could be damaged and quality warranty will be invalid.

#### 5.3.1 Bolts Mounting.

Apply bolts to fix modules on the bracket through mounting holes on the back frame. See details in Figure 10. A is the overlapping size of module frame and bracket.

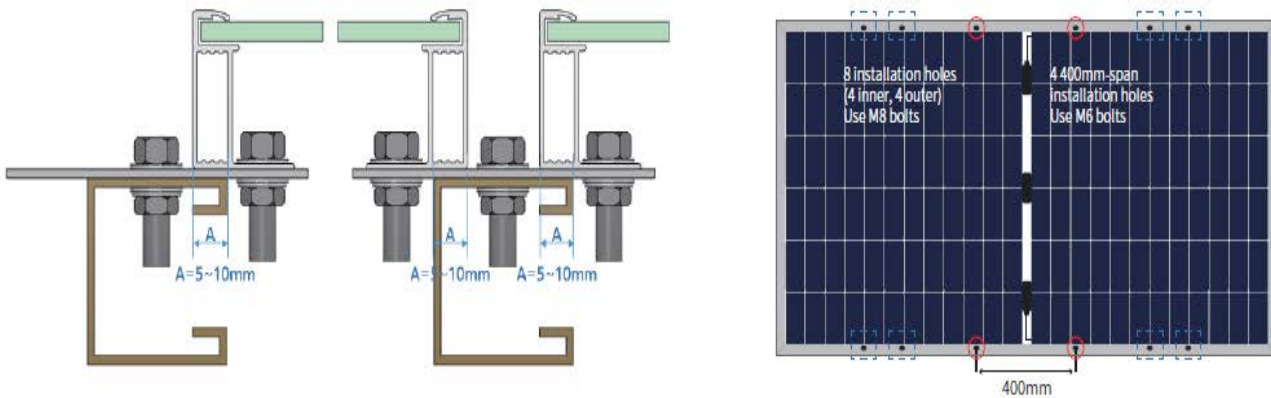

Figure 10 Bolt Installation of Bifacial Module



Figure 11 Sketch Map of Installation of Bifacial Module



Recommended accessories are as below:

Accessories	Model		Material	Note
Bolt	M8 (full thread recommended)	M6 (full thread recommended)	Q235B/SUS304	Accessories material selection should be based on application environment.
Washer	2*8	2*6 (6.4*18-1.6 ISO 7093)	Q235B/SUS304	
Spring Washer	8	6	Q235B/SUS304	
Nut	M8	M6	Q235B/SUS304	

Table 4 Recommended accessories for installation of Bifacial Module

Suggestion:

- (1) M8 bolt tightening torque range: 14N•m-18N•m; M6 bolt tightening torque range: 8N•m-12N•m;
- (2) When using Ulica 30mm (30H) height frame module, it is recommended to select  $L \leq 20\text{mm}$  length fasteners. (If there is a special model, consult Ulica customer service).

### 5.3.2 Clamps Installation

See details in Figure 12.

The clamp shall not be in touch with glass or deform module frame in any case. The interface of the clamp and frame front side shall be flat and smooth to prevent frame and module being damaged.

Avoid the shadow blocking effect of the clamp.

The drain hole cannot be blocked by the clamp. For framed PV module, the clamp must maintain an overlap of at least 8 mm but no more than 11 mm with the frame of the module (you can change the cross section of the fixture if the module is securely installed). For frameless PV module, the clamp must maintain an overlap of 15 mm at maximum with the module.

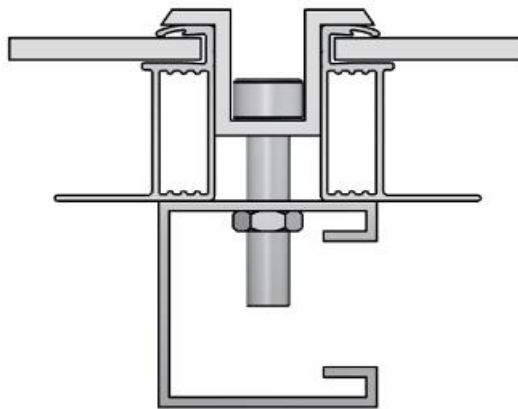
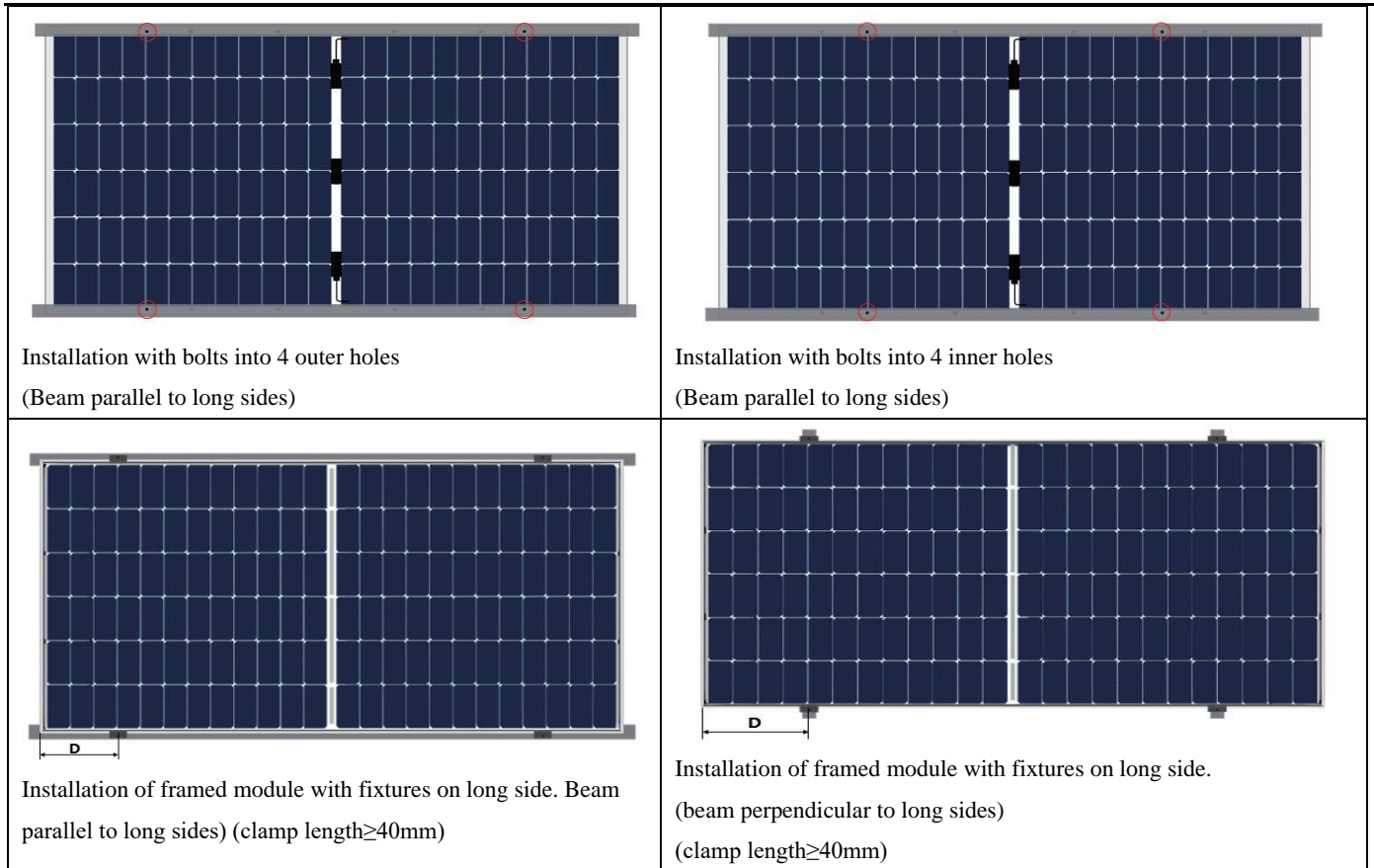

Figure 12 Clamp Installation of Bifacial Module

### 5.3.3 Installation and Mechanical Load of Bifacial Module

Bifacial modules can be installed with bolts into 4 outer installation holes, bolts into 4 inner installation holes, bolts into 400mm-span installation holes, and fixtures. Detailed installation positions and corresponding load capacities are shown in the table below.



Load capacities of framed Bifacial Double-Glass modules:

Installation Method Module Type	Installation with bolts		Installation with fixtures	
	Installation with bolts into 4 outer holes (Beam parallel to long sides)	Installation with bolts into 4 inner holes (Beam parallel to long sides)	Installation of framed module with fixtures on long side. Beam parallel to long sides) $1/4L-50 \leq D \leq 1/4L+50$ (Beam parallel to long sides)	Installation of framed module with fixtures on long side. (beam perpendicular to long sides) $.350 \leq D \leq 450$ ( beam perpendicular to long sides )
<b>UL-xxx M-120B (166)</b>	Down force load $\leq 2400\text{Pa}$ , Uplift load $\leq 2400\text{Pa}$	Down force load $\leq 2400\text{Pa}$ , Uplift load $\leq 2400\text{Pa}$	Down force load 2400Pa, Uplift load $\leq 2400\text{Pa}$	Down force load $\leq 5400\text{Pa}$ , Uplift load $\leq 2400\text{Pa}$
<b>UL-xxx M-108B (182)</b>	Down force load $\leq 2400\text{Pa}$ , Uplift load $\leq 2400\text{Pa}$	Down force load $\leq 2400\text{Pa}$ , Uplift load $\leq 2400\text{Pa}$	Down force load 2400Pa, Uplift load $\leq 2400\text{Pa}$	Down force load $\leq 3600\text{Pa}$ , Uplift load $\leq 2400\text{Pa}$
<b>UL-xxx M-132B (182)</b>	Down force load $\leq 2400\text{Pa}$ , Uplift load $\leq 2400\text{Pa}$	Down force load $\leq 2400\text{Pa}$ , Uplift load $\leq 2400\text{Pa}$	Down force load 2400Pa, Uplift load $\leq 2400\text{Pa}$	Down force load $\leq 3600\text{Pa}$ , Uplift load $\leq 2400\text{Pa}$
<b>UL-xxx M-144B (166)</b>	Down force load $\leq 2400\text{Pa}$ , Uplift load $\leq 2400\text{Pa}$	Down force load $\leq 2400\text{Pa}$ , Uplift load $\leq 2400\text{Pa}$	Down force load 2400Pa, Uplift load $\leq 2400\text{Pa}$	Down force load $\leq 3600\text{Pa}$ , Uplift load $\leq 2400\text{Pa}$
<b>UL-xxx M-144B (182)</b>	Down force load $\leq 2400\text{Pa}$ , Uplift load $\leq 2400\text{Pa}$	Down force load $\leq 2400\text{Pa}$ , Uplift load $\leq 2400\text{Pa}$	Down force load 2400Pa, Uplift load $\leq 2400\text{Pa}$	Down force load $\leq 3600\text{Pa}$ , Uplift load $\leq 2400\text{Pa}$

## 6. Electrical installation

### 6.1 Electrical Performance

The reported performance measurements are subject to  $\pm 3\%$  uncertainty at STC (1000 W/m<sup>2</sup> Irradiance, a cell temperature of 25°C and an AM1.5 spectrum) for voltage, current and power.

When modules are in series connection, the string voltage is sum of every individual module in one string. When modules are in parallel connection, the current is sum of the individual module as shown in below figure 13. Modules with different electric performance models can not be connected in one string.

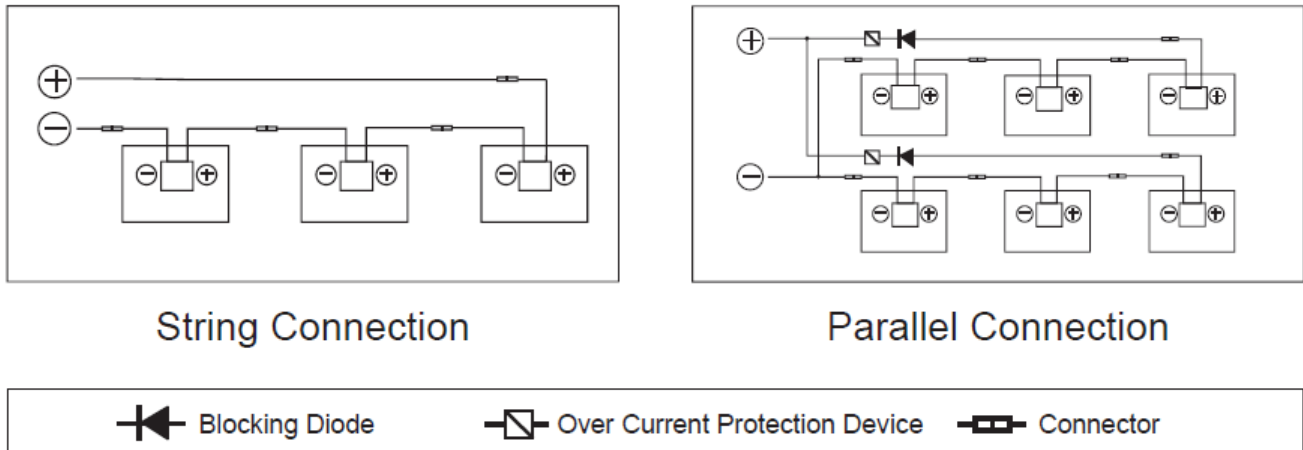

Figure 13 Series Connection and Parallel Connection Circuit Diagram

The maximum allowed quantity of modules in string connection shall be calculated according to relative regulations. The open circuit voltage value under the expected lowest temperature shall not exceed the maximum system voltage value allowed by modules and other values required by DC electric parts. (Ulica modules maximum system voltage is DC1000V/DC1500V---actually system voltage is designed based on the selected module and inverter model.) The VOC factor can be calculated by the following formula.  $C_{Voc} = 1 - \beta V_{oc} \times (25 - T)$  T: The expected lowest temperature of the installation site.  $\beta$ : VOC temperature coefficient (% /°C) (Refer to modules data sheet for further detail) If there is reverse current exceeding the maximum fuse current flowing through the module, use over current protection device with the same specifications to protect the module; if parallel connection are more than 2, there must be an over current protection device on each string of module.

## 6.2 Cables and Wiring

In module design, adopt junction boxes with the protective level of IP67 for on-site connection to provide environmental protection for wires and connections and contacting protection for non-insulating electric parts. The junction box perform the protective level of IP67 with well connected cables and connectors. These designs facilitate parallel connection of modules. Each module has two individual wires connecting the junction box, one is negative pole and the other is positive pole. Two modules can be in series connection by inserting the positive pole at one end of wire of one module into the negative pole of the adjoining module.

According to local fire protection, building and electrical regulation, apply proper cable and connector; ensure the electrical and mechanical property of the cables (the cables should be put in a catheter with anti-UV aging properties, and if exposed to air, the cable itself should have anti-UV aging capability). The installer can only use single-wire cable, 2.5-16mm<sup>2</sup>(5-14 AWG), 90 °C , with proper insulation capability to withstand the maximum open circuit voltage (such as EN50618 approval). Need to select appropriate wire specifications to reduce voltage drop.

Ulica requires that all wiring and electrical connections comply with the appropriate ‘National Electrical Code’.

When cables are fixed on the bracket, avoid mechanical damaging cables or modules. Do not press cables by force. Adopt UV resistant cable ties and clamps to fix cables on the bracket. Though cables are UV resistant and water proof, it is still necessary to prevent cables from direct sun light and water immersion. The minimum bending radius of cables should be 43mm. (1.69in)

### **6.3 Connector**

Please keep connectors clean and dry. Make sure connector caps are fastened before connection. Do not connect connectors under improper conditions of damp, dirty or other exceptional situations ). Avoid connectors from direct sun light and water immersion or falling onto ground or roof.

Incorrect connection may lead to electric arc and electric shock. Please make sure that all electric connection is reliable.

Make sure all connectors are fully locked.

Only compatible connectors can be mated, i.e. from the same vendor and model, shall be used;(If you need to use different types of connectors, please consult customer service of Ulica solar ).

### **6.4 Bypass diode**

Ulica solar module junction box contains bypass diode which is in parallel connection with the cell string. If hot spot occurred, the diode will come into operation to stop the main current from flowing through the hot spot cells in order to prevent module over-heated and performance loss. Notice, bypass diode is not the overcurrent protection device.

If the diode is definite or suspected to be defective, the installer or system maintenance supplier shall contact Ulica.

Please do not try to open the module junction box on your own.

### **6.5 PID**

Protection and Inverter Compatibility.

PV modules may appear Potential Induced Degradation (PID) under high humidity, high temperature and high voltage condition. Modules may appear Potential Induced Degradation (PID) under the conditions below:

6.5.1 PV modules install under hot and humid weather condition.

6.5.2 PV modules installation site is under long term humid condition such as floating PV system.

6.5.3 To reduce the risk of PID, on the modules DC connection site, it is recommended to connect the negative to ground.

The PID protection measures on system level are recommended as follow:

(1) For isolated PV inverter, the negative of the PV modules DC connection side can be directly grounded.

(2) For non-isolated PV inverter, isolated transformer is needed to be installed before applying virtual grounding (grounding method guidance from the inverter manufactures are usually needed).

## **7. Grounding**

In design of modules, the anodized corrosion resistant aluminum alloy frame is applied for rigidity support. For safety utilization and to protect modules from lightning and static-electricity damage, the module frame must be grounded.

The grounding device must be in full contact with inner side of the aluminum alloy and penetrate surface oxide film of the frame.

Do not drill additional grounding holes on module frame.

The grounding conductor or wire may be copper, copper alloy, or any other material acceptable for application as an electrical conductor per respective National Electrical Codes. The grounding conductor must then make a connection to ground with a suitable ground electrode.

Holes marked with a grounding mark on the frame can only be used for grounding but not for mounting. Frameless double glass modules have no exposed conductor, and therefore according to regulations it did not need to be grounded.

**Grounding methods below are permissible:**

(1) Grounding by grounding clamp.

There is a grounding hole with the diameter of  $\varnothing 4.2$  mm at the edge of the module back frame. The central line of the grounding sign also located on the edge of the module back frame overlaps with that of the grounding hole.

Grounding between modules shall be confirmed by qualified electricians and grounding devices shall be manufactured by qualified electric manufacturer. The torque of copper core wire used for the grounding clamp is recommended to be  $2.3N \cdot m$ . 12 AWG. And copper wires cannot be pressed during installation in case of damaging.

(2) Grounding by unoccupied mounting holes .

Mounting holes on modules that are not occupied can be used for installing grounding components.

- ◆ Align grounding clamp to the frame mounting hole. Use grounding bolt to go through the grounding clamp and frame.
- ◆ Put the tooth side of the washer on the other side and fasten the nuts.
- ◆ Put grounding wires through the grounding clamp and grounding wire material and dimension shall meet requirements in local national and regional law and regulations.
- ◆ Fasten bolts of grounding wires and then installation is completed.

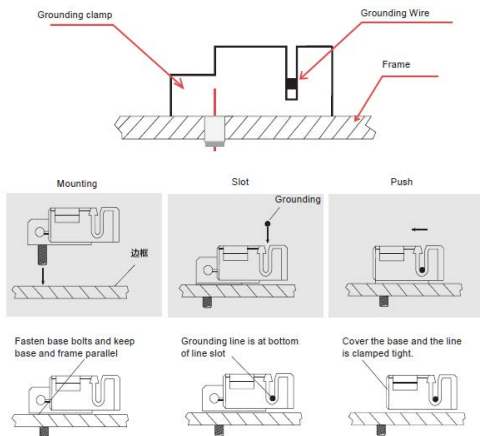

Figure 14 Clamp Grounding Method

Note: TYCO. 1954381-1 (Recommended) is used in figures above.

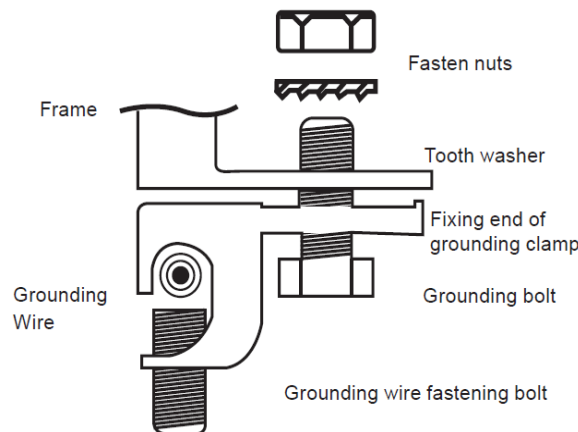

Figure 15 Bolt Grounding Method

**The third party grounding devices**

The third party grounding device can be used for grounding of Ulica modules but such grounding shall be proved to be reliable. Grounding device shall be operated in line with stipulations of the manufacturer.

**8. Operation and maintenance**

It is the users' responsibility to carry out regular inspection and maintenance for modules, especially during the period of limited warranty; inform the supplier within two weeks when modules are found broken.

**8.1 Cleaning**

Accumulated contaminants on module surface glass will reduce the power output and lead to local hot spot, such as dust, industrial wasted water and birds' droppings. The severity of influence is determined by transparency of wastes. Small amounts of dust will affect the intensity and evenness of received solar irradiation but are not dangerous and power will not be reduced remarkably generally.

During operation of modules, there shall be no environmental factors to shade modules fully or partially. These environment factors including other modules, module mounting system, birds dwelling, dust, soil or plants. These will significantly reduce output power. Ulica suggests that the module surface should not be shadowed in any case.

Frequency of cleaning depends on dirt accumulation speed. In normal situations, rainwater will clean the module surface and reduce the cleaning frequency. It is suggested to use sponge dipped with clean water or soft cloth to wipe the glass surface. Do not use acid and alkaline detergents to clean modules. Do not use tool with rough surface to clean in any case.

In order to avoid potential risk of electrical shock or burn, Ulica suggests cleaning the modules during early morning and evening with low irradiance and low modules temperature especially area with high average temperature.

In order to avoid potential risk of electrical shock, do not try to clean the modules with glass damage or expose wires.

## **8.2 Module Appearance Inspection**

Check module cosmetic defects with naked eyes, especially:

- 8.2.1 Module glass cracks.
- 8.2.2 Corrosion at welding parts of the cell main grid, caused by moisture into the module due to damage of sealing materials during installation or transportation.
- 8.2.3 Check whether there are traces of burning mark on the module back sheet.
- 8.2.4 Check PV modules if any signs of aging including rodent damage, climate aging, connectors tightness, corrosion and grounding condition.
- 8.2.5 Check if any sharp objects in contact with PV modules' surface.
- 8.2.6 Check if any obstacles shading the PV modules.
- 8.2.7 Check if any loose or damage screws between the modules and mounting system. If so, adjust and fix in time.

## **8.3 Inspection of Connectors and Cables**

It is suggested to carry out the following preventive inspection twice a year:

- Check if any crack or gap of silicone nearby the junction box.

## **9. Release and execution**

This manual document is implemented and managed by product management department. Product management department reserves the right to modify and revise in any time.

### **Ningbo Ulica Solar Co., Ltd.**

Add: Block A1, No.218 Middle Yunlin Road, Haishu District, 315177-Ningbo, CHINA

Tel: 86-574-28828976

Fax: 86-574-28828997





## HM-1000/1200/1500

The Best in Its Class! The Microinverter  
with reactive power control for 4 solar panels

### Highlights

- Easy installation, just plug and play
- External antenna for stronger communication with DTU
- Power factor (adjustable) 0.8 leading.....0.8 lagging
- The highest power density microinverter on the market
- Compliant with VDE-AR-N 4105: 2018 & EN50549-1: 2019
- High reliability; NEMA (IP67) enclosure; 6000V surge protection



Safer



Smarter



More Powerful



More Reliable



Model	HM-1000	HM-1200	HM-1500
-------	---------	---------	---------

**Input Data (DC)**

Commonly used module power (W)	200~310	240~380	300~470
Module compatibility	60-cell or 72-cell PV modules	60-cell or 72-cell PV modules	60-cell or 72-cell PV modules
Peak power MPPT voltage range (V)	27~48	29-48	36~48
Start-up voltage (V)	22	22	22
Operating voltage range (V)	16~60	16-60	16~60
Maximum input voltage (V)	60	60	60
Maximum input current (A)	4*10.5	4*11.5	4*11.5

**Output Data (AC)**

Rated output power (VA)	1000			1200			1500		
Rated output current(A)	4.55	4.35	4.17	5.45	5.22	5	6.82	6.52	6.25
Nominal output voltage/range (V)	220/180-275 <sup>1</sup>	230/180-275 <sup>1</sup>	240/180-275 <sup>1</sup>	220/180-275 <sup>1</sup>	230/180-275 <sup>1</sup>	240/180-275 <sup>1</sup>	220/180-275 <sup>1</sup>	230/180-275 <sup>1</sup>	240/180-275 <sup>1</sup>
Nominal frequency/range (V)	50/45-55 <sup>1</sup> or 60/55-65 <sup>1</sup>			50/45-55 <sup>1</sup> or 60/55-65 <sup>1</sup>			50/45-55 <sup>1</sup> or 60/55-65 <sup>1</sup>		
Power factor (adjustable)	>0.99 default 0.8 leading...0.8 lagging			>0.99 default 0.8 leading...0.8 lagging			>0.99 default 0.8 leading...0.8 lagging		
Total harmonic distortion	<3%			<3%			<3%		
Maximum units per branch <sup>2</sup>	5	5	5	4	4	4	3	3	3

**Efficiency**

CEC peak efficiency	96.70%	96.70%	96.70%
CEC weighted efficiency	96.50%	96.50%	96.50%
Nominal MPPT efficiency	99.80%	99.80%	99.80%
Nighttime power consumption (mW)	<50	<50	<50

**Mechanical Data**

Ambient temperature range (°C)	-40~+65
Dimensions (W×H×D mm)	280 x 176 x 33
Weight (kG)	3.75
Enclosure rating	Outdoor-NEMA (IP67)
Cooling	Natural convection – No fans

**Features**

Communication	2.4GHz Proprietary RF(Nordic)
Monitoring	Hoymiles Monitoring System
Compliance	VDE-R-N 4105: 2018, EN 50549-1: 2019, VFR 2019, IEC/EN 62109-1/-2, IEC/EN 61000-6-1/-2/-3/-4, IEC/EN 61000-3-2/-3

\*1 Nominal voltage/frequency range can be changed due to the requirements of local power department.

\*2 Refer to local requirements for exact number of microinverters per branch.

High Reliability Based on World's Top Supplier Partners

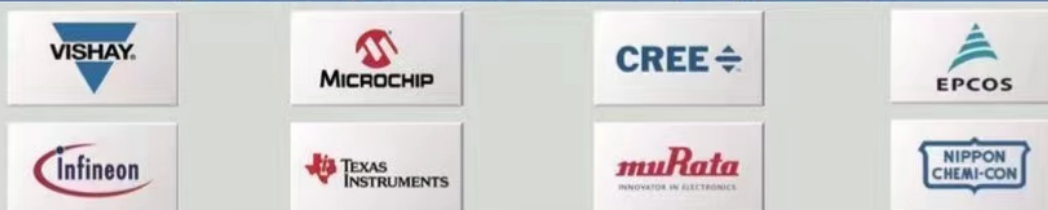

# LR4-60HPH 350~380M

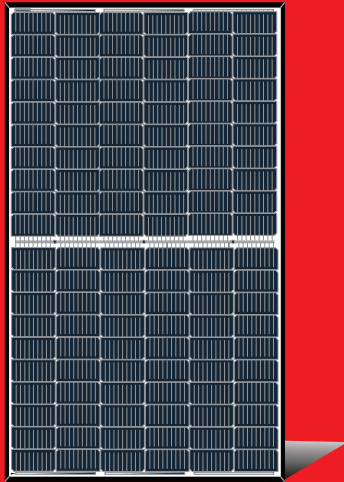

\*Both 6BB & 9BB are available

**High Efficiency  
Low LID Mono PERC with  
Half-cut Technology**

10-year Warranty for Materials and Processing;  
25-year Warranty for Extra Linear Power Output

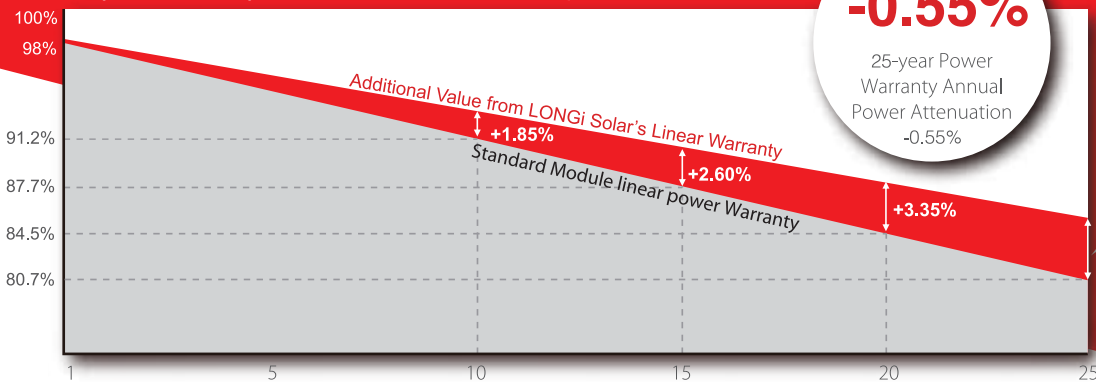

### Complete System and Product Certifications

IEC 61215, IEC61730, UL61730  
ISO 9001:2008: ISO Quality Management System  
ISO 14001: 2004: ISO Environment Management System  
TS62941: Guideline for module design qualification and type approval  
OHSAS 18001: 2007 Occupational Health and Safety



\* Specifications subject to technical changes and tests. LONGi Solar reserves the right of interpretation.

**Positive power tolerance** (0 ~ +5W) guaranteed

**High module conversion efficiency** (up to 20.9%)

**Slower power degradation** enabled by Low LID Mono PERC technology: first year <2%, 0.55% year 2-25

**Solid PID resistance** ensured by solar cell process optimization and careful module BOM selection

**Reduced resistive loss** with lower operating current

**Higher energy yield** with lower operating temperature

**Reduced hot spot risk** with optimized electrical design and lower operating current



Room 801, Tower 3, Lujiazui Financial Plaza, No.826 Century Avenue, Pudong Shanghai, 200120, China  
Tel: +86-21-80162606 E-mail: module@longi-silicon.com Facebook: www.facebook.com/LONGi Solar

Note: Due to continuous technical innovation, R&D and improvement, technical data above mentioned may be of modification accordingly. LONGi have the sole right to make such modification at anytime without further notice; Demanding party shall request for the latest datasheet for such as contract need, and make it a consisting and binding part of lawful documentation duly signed by both parties.

# LR4-60HPH 350~380M

## Design (mm)

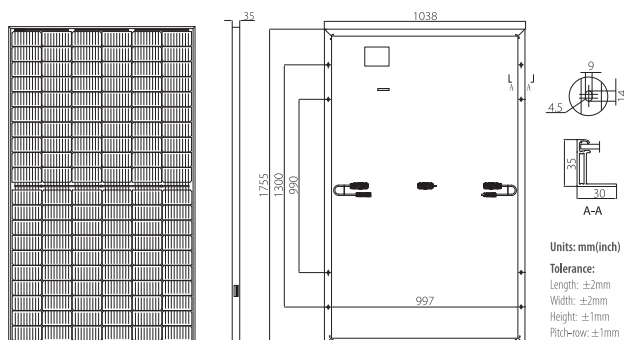

## Mechanical Parameters

Cell Orientation: 120 (6×20)  
 Junction Box: IP68, three diodes  
 Output Cable: 4mm<sup>2</sup>, 1200mm in length  
 for EU DG  
 Glass: Single glass  
 3.2mm coated tempered glass  
 Frame: Anodized aluminum alloy frame  
 Weight: 19.5kg  
 Dimension: 1755×1038×35mm  
 Packaging: 30pcs per pallet  
 180pcs per 20'GP  
 780pcs per 40'HC

## Operating Parameters

Operational Temperature: -40°C ~ +85°C  
 Power Output Tolerance: 0 ~ +5 W  
 Voc and Isc Tolerance: ±3%  
 Maximum System Voltage: DC1500V (IEC/UL)  
 Maximum Series Fuse Rating: 20A  
 Nominal Operating Cell Temperature: 45±2°C  
 Safety Class: Class II  
 Fire Rating: UL type 1 or 2

## Electrical Characteristics

Test uncertainty for Pmax: ±3%

Model Number	LR4-60HPH-350M		LR4-60HPH-355M		LR4-60HPH-360M		LR4-60HPH-365M		LR4-60HPH-370M		LR4-60HPH-375M		LR4-60HPH-380M	
Testing Condition	STC	NOCT	STC	NOCT	STC	NOCT	STC	NOCT	STC	NOCT	STC	NOCT	STC	NOCT
Maximum Power (Pmax/W)	350	259.3	355	263.0	360	266.7	365	270.4	370	274.1	375	277.8	380	281.5
Open Circuit Voltage (Voc/V)	40.1	37.4	40.3	37.6	40.5	37.8	40.7	38.0	40.9	38.2	41.1	38.4	41.3	38.5
Short Circuit Current (Isc/A)	11.15	9.00	11.25	9.07	11.35	9.15	11.43	9.22	11.52	9.29	11.60	9.35	11.69	9.42
Voltage at Maximum Power (Vmp/V)	33.6	31.0	33.8	31.2	34.0	31.4	34.2	31.6	34.4	31.8	34.6	32.0	34.8	32.1
Current at Maximum Power (Imp/A)	10.42	8.35	10.51	8.43	10.59	8.49	10.68	8.56	10.76	8.63	10.84	8.69	10.92	8.76
Module Efficiency(%)	19.2		19.5		19.8		20.0		20.3		20.6		20.9	

STC (Standard Testing Conditions): Irradiance 1000W/m<sup>2</sup>, Cell Temperature 25°C, Spectra at AM1.5

NOCT (Nominal Operating Cell Temperature): Irradiance 800W/m<sup>2</sup>, Ambient Temperature 20°C, Spectra at AM1.5, Wind at 1m/s

## Temperature Ratings ( STC )

Temperature Coefficient of Isc: +0.048%/°C  
 Temperature Coefficient of Voc: -0.270%/°C  
 Temperature Coefficient of Pmax: -0.350%/°C

## Mechanical Loading

Front Side Maximum Static Loading: 5400Pa  
 Rear Side Maximum Static Loading: 2400Pa  
 Hailstone Test: 25mm Hailstone at the speed of 23m/s

## I-V Curve

Current-Voltage Curve (LR4-60HPH-365M)

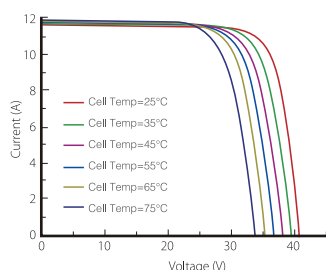

Power-Voltage Curve (LR4-60HPH-365M)

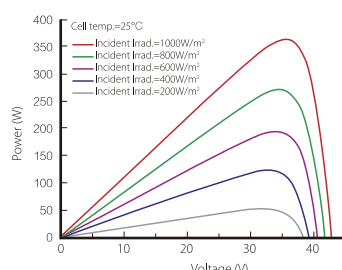

Current-Voltage Curve (LR4-60HPH-365M)

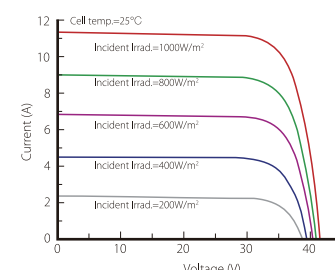

Room 801, Tower 3, Lujiazui Financial Plaza, No.826 Century Avenue, Pudong Shanghai, 200120, China  
 Tel: +86-21-80162606 E-mail: module@longi-silicon.com Facebook: www.facebook.com/LONGI Solar

Note: Due to continuous technical innovation, R&D and improvement, technical data above mentioned may be of modification accordingly. LONGI have the sole right to make such modification at anytime without further notice; Demanding party shall request for the latest datasheet for such as contract need, and make it a consisting and binding part of lawful documentation duly signed by both parties.